

dnd







































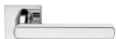







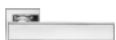















18-
19

dnd

18-
19

indice / index

design

aretè		96	ego		198	joy		148	project 02		174
aretè 02		98	esa		136	joy 02		150	project zancata		176
aretè L		102	esa due		134	linear		154	safety		56
aretè L 02		104	fluke		124	logo		178	short		170
art		152	fluò		200	logo 02		180	sike		164
blip		158	fold		144	luce		128	sike 02		166
boole		52	fold 02		146	luce 02		130	sochic		186
C-1918		82	ginkgo		60	lucrezia		76	sochic L		188
change 02		114	ginkgo biloba		64	lucrezia 02		78	stick 02		208
change B 02		116	go		202	luxury		90	timeless		68
chop		142	grip		206	luxury 02		92	twist		160
cloe		108	havana		182	madeleine		48	twist 02		162
cloe 02		110	holly		138	minima		140	vita		190
dolce		156	intake		86	mix		204	vita 02		192
edra 02		120	isabella		72	movida		184	vita B		194

classic

airone		240	fiorenza		212
appia		234	katy		252
ardea		224	lady		230
beauty		248	latina		232
beverly		228	lirica		218
bruxelles		250	lorena		242
cassia		226	monica		236
classic		220	sinfonia		238
classic due		222			
daniela		244			
daniela p.		246			
fedora		216			
fiore		214			

professional

arcadia		261	nova O2 / nova B O2		258
artik		260	noxia		260
carola		259	polo		262
diana		261	quattro O2 Z		257
elena		261	round		262
fast		259	S40		256
handy		259	S50		256
handy O2 Z		260	S60		256
kristina		263	sabina		263
laura		264	tema		258
link / link B		257	tipo		258
nina		264	venice		262
nova / nova B		257	wing		263

Combinazioni
particolari
Combinations 268

Maniglie per finestre
Windows handles 274

Maniglioni
Pull handles

aretè	290
aretè L	291
art	306
beverly	310
beverly corto	311
C-1918	294
C-1918 zancato	295
cloe	286
daniela	314
domus	308
elena	319
fluke	297
go	307
intake	293
katy	315
latina	316
linear	304
lirica	312
lirica corto	313

logo	302
logo B	303
luce	296
lucrezia	309
luxury	292
only	318
project	298
project spostato	299
ring	300
rondò	301
sabina	317
solid flat	288
solid round	289
solid square	287



Maniglioni per
alzante scorrevole
*Pull handles for
lift sliding system*

edra	322
edra corto	323
edra 02	324
edra 02 corto	325
liter	330
luce	326
luce 02	327
slide	328
slide corto	329
nicchie	331

Pomoli
Knobs

art	336
diamante	340
easy	337
fiorenza	340
fluò	336
go	337
lucrezia	334
lucrezia O2	334
ovale centrale	341
project	338
quadro	339
ring	335
rondò	335
sfera	339
timeless 	338
victorian	341
Accessori per mobili <i>Furniture accessories</i>	342

Maniglie per porte scorrevoli
Sliding door handles

ginkgo quadra 	348
ginkgo tonda 	346
noxia	359
quadra	354
rettangolare	358
ring	350
rondò	352
tonda	356
serrature	360

Articoli vari
Other complements

Battenti <i>Door knockers</i>	364
Portabiti <i>Coat hangers</i>	366
Nottolini <i>Turn & releases</i>	368
Bocchette <i>Escutcheons</i>	380
Fermaporta <i>Door stop</i>	386
Chiavi <i>Keys</i>	387
Supporti corrimano <i>Handrail brackets</i>	387
Cerniere <i>Hinges</i>	388
Placche <i>Plates</i>	390
Espositori <i>Displays</i>	391

azienda / company

Esistono territori in Italia dove la combinazione tra la storia e le storie degli uomini è diventata una mirabile fusione: uno di quei luoghi è la Val Sabbia, territorio prealpino bresciano racchiuso tra il lago di Garda a est e la Val Trompia a ovest. Una valle caratterizzata da un'antica dedizione per la trasformazione dei metalli, le lavorazioni siderurgiche, la generazione di oggetti forti – ottenuti a colpi di maglio, fusione, pressofusione – in antiche fucine che nel tempo si sono trasformate in solide realtà industriali. È in questo contesto che si innesta la storia di Angelo Martinelli che, con i fratelli, nel 1968 fonda a Nozza l'azienda FMN Martinelli (Fratelli Martinelli Nozza), specializzata nella produzione di maniglie e accessori per porte e finestre. Nel 1998 viene creato il marchio Dnd con l'obiettivo di proporre al mercato oggetti di alta qualità, con la collaborazione di validi progettisti.

Oggi Dnd, condotta da Vilma Martinelli, è un'importante azienda con cinquant'anni di storia. I figli Pietro e Simona – la terza generazione della famiglia – sono attivamente inseriti e creano un felice connubio tra sapienza artigianale, esperienza e innovazione. Una realtà che si è evoluta e concentrata sullo sviluppo della produzione, rinnovando i processi produttivi e specializzandosi nella lavorazione dei nuovi e diversi metalli destinati alla produzione delle maniglie. Se inizialmente è stato il territorio ad aver ispirato la creazione dell'azienda, oggi è l'azienda che restituisce alla Val Sabbia un ruolo chiave per lo sviluppo dei prodotti, incoraggiando e sostenendo una rete di realtà artigianali a cui demandare specifici passaggi di produzione e finitura: un indotto che costituisce un grande valore, ideale estensione e completamento di un processo che garantisce l'eccellenza dei prodotti che Dnd, con la sua ricerca, mira a realizzare. L'azienda, anche grazie ai suoi validi collaboratori interni, intende oggi essere una fucina di idee per il progetto contemporaneo, italiano e internazionale: una sapienza produttiva al servizio della creatività di designer e architetti di valore con cui Dnd intende instaurare un rinnovato e solido rapporto, guardando al futuro con fiducia e curiosità.

There are territories in Italy where the combination of history and the stories of people has become an admirable blend: one of those places is Val Sabbia, a pre-Alpine zone near Brescia bordered by Lake Garda to the east and Val Trompia to the west. A valley known for its historic vocation for the working of metals, the making of steel, the generation of strong objects – made by wielding a hammer, by casting, by die-casting – in old forges that have been transformed, over time, into solid industrial companies. This is the context for the story of Angelo Martinelli, who with his brothers, in 1968, in the town of Nozza, founded the company FMN Martinelli (Fratelli Martinelli Nozza), specializing in the production of handles and accessories for doors and windows. The Dnd trademark was created in 1998, with the aim of offering high-quality products on the market, thanks to collaboration with outstanding designers.

Today Dnd, helmed by Vilma Martinelli, is an important company with 50 years of history. Son and daughter Pietro and Simona – the third generation of the family – play an active role, creating a successful balance of craftsmanship, experience and innovation. A company that has evolved and concentrated on developing production capacity, updating processes and specializing in the shaping of new, different metals with which to make handles.

While at first it was the territory that drove the creativity of the company, today it is the company that plays a key role in Val Sabbia for the development of products, encouraging and supporting a network of crafts firms from which to order specific phases of production and finishing: a chain of manufacture that represents a remarkable value, an ideal extension and completion of a process that ensures the excellence of the products that Dnd, through its research, sets out to create. Today, also thanks to the expertise of the in-house staff, the company strives to be a forge of ideas for Italian and international contemporary design: a case of productive know-how at the service of the creativity of outstanding designers and architects, with whom Dnd establishes ongoing and solid relationships, looking to the future with confidence and curiosity.



**Azienda con
certificazione
sistema di qualità
UNI EN ISO 9001**

- Progettazione ottimizzata
- Costante formazione delle risorse umane
- Ambiente di lavoro controllato
- Produzione tecnologicamente avanzata
- Monitoraggio instancabile

**A company with
UNI EN ISO 9001
quality system
certification**

- *Optimized design*
- *Constant training of human resources*
- *Controlled working environment*
- *Technologically advanced production*
- *Continuous monitoring*



identità / identity

La nuova immagine coordinata di Dnd racconta la volontà di aderire in modo esemplare al mondo del miglior design contemporaneo. Un'immagine chiara, forte e solida che si irradia in ogni spazio di rappresentazione dell'azienda. Il nuovo logotipo, disegnato da Leonardo Sonnoli, presenta un nome aziendale rinnovato e una lettera d che si inclina come una maniglia in azione. Un logotipo che indica una direzione – il futuro – e che al tempo stesso denota un presente dinamico.

Il catalogo, impostato come un ambiente grafico dal forte nitore, diventa il luogo ideale dove le maniglie – e i valori formali e di finitura che esse sottendono – possono emergere al meglio. Un catalogo che vuole essere una dichiarazione di intenti, a segnare un prima e un dopo nel mondo di chi produce e ama le maniglie: un libro dedicato a un oggetto che è in grado di trasformare la percezione di uno spazio, per entrare nel prossimo futuro e nella storia del domani di Dnd.

The new coordinated image of Dnd reflects a desire to play an exemplary role in the world of the best contemporary design. A clear, strong, solid image that shines through in every space of representation of the company. The new logo designed by Leonardo Sonnoli features an updated company name and a letter 'd' at an angle, like a handle during use. A logo that indicates a direction – the future – while at the same time embodying a dynamic present.

The catalogue, approached as a graphic environment of forceful clarity, becomes the ideal setting in which the handles – with their underlying values of form and finish – can be seen to best advantage. A catalogue that sets out to convey a statement of intent, marking a before and after in the world of those who produce handles, and those who love them: a book about an object that is capable of transforming our perception of a space, to enter the near future and the history of tomorrow of Dnd.



Il primo logotipo dell'azienda, **1968**

The first logo, 1968



Il nuovo logotipo dell'azienda, **2018**

The new logo, 2018

dnd

Sistemi per porte e finestre

– Door and window systems

Sistema Less is fine 4 mm /
Less is fine system 4 mm

FINE

FINE

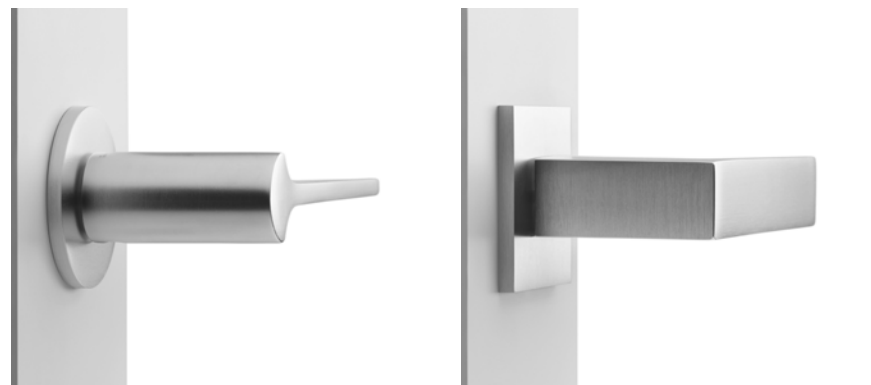

Il sistema Less is fine – di soli 4 mm – nasce grazie alle nuove tendenze dell'architettura. In soli 4 mm si trova la rosetta metallica con doppia molla di ritorno – a compressione –, la quale permette un'installazione senza lavorazioni aggiuntive sulla porta. Brevetto Dnd.

The Less is fine system has a thickness of just 4 mm. It has been developed in tune with the latest design trends. A patented double spring-loaded metal backplate facilitates installation. Dnd patent.

Sistema VIS 7 mm / VIS 7 mm system

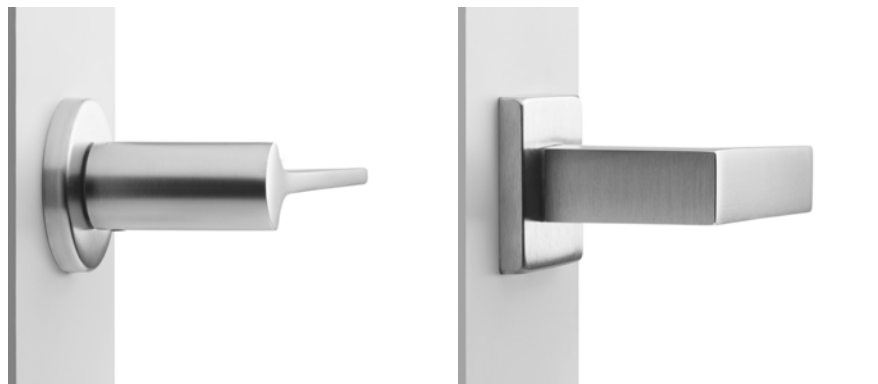

Componenti realizzati in nylon PA6 con molla uni-direzionale destra o sinistra. Rosette con diametro 50 mm e spessore 7 mm. Fori per fissaggio legno e interasse 38 mm per viti a connessione con o senza bussole. Il sistema e la molla interna sono stati testati e certificati dal Laboratorio AQM - Cert.2012-1000/PPE, in base all'normativa UNI EN 1906.

The parts are made with PA6 nylon, with uni-directional left or right spring. The backplate has a diameter of 50 mm and a thickness of 7 mm. Holes for attachment to wood, 38 mm centering, with or without connector nuts. The inner spring and system are certified by AQM - Cert.2012-1000/Ppe in keeping with UNI EN 1906 standards.

Test di tenuta e usura dei componenti meccanici. Simulazione di apertura e chiusura oltre 200.000 cicli.

probabilità d'uso improprio.
Durabilità Grado 7: frequenza d'uso elevata 200.000 cicli.

Categoria d'uso Grado 3: alta frequenza d'uso da parte del pubblico o scarsa cura; alte

Azionamento Tipo B, serrature caricate a molla.

Mechanical components wear and tear test. Opening and closing simulation to more than 200.000 cycles.

Category of use Grade 3: High frequency of use by the public or others with little incentive to

exercise care and with a high chance of misuse.

Durability Grade 7: high frequency of use 200.000 cycles.

Type of operation B spring-loaded furniture.

Sistema 52 - 10 mm / 52 - 10 mm system

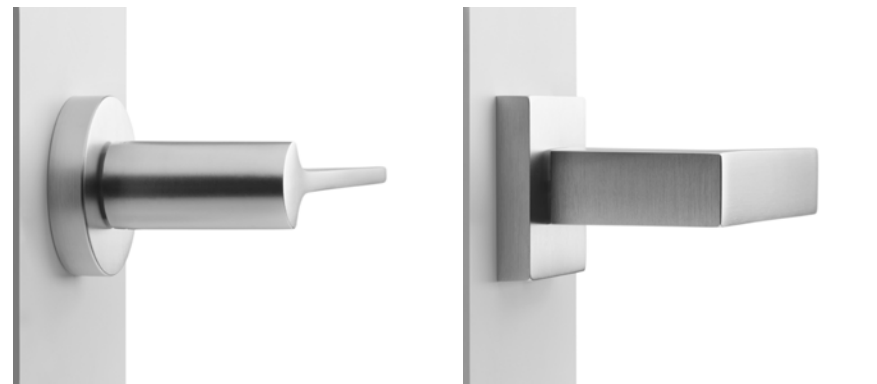

Componenti realizzati in metallo con molla bi-direzionale destra/sinistra. Rosette con diametro 52 mm e spessore 10 mm. Fori per fissaggio legno e interasse 38 mm per viti a connessione con o senza bussole.

The parts are in metal, with bi-directional left/right spring. The backplates have a diameter of 52 mm and a thickness of 10 mm. Holes for attachment to wood, 38 mm centering, with or without connector nuts.

Componenti tecnici / Technical components

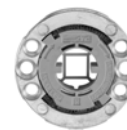

Less is fine



VIS



VIS

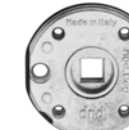

52

DK VIS 9 mm

VIS VIS



Il DK VIS nasce dall'esigenza di ottenere un sistema esteticamente combinato con il sistema VIS per porta.

Le componenti tecniche restano così più discrete e lasciano pieno spazio al design della maniglia. Un meccanismo facile e veloce da montare, senza la necessità di lavorazioni sul serramento.

DK VIS is the result of the need for aesthetic coordination with the VIS system for doors. The technical components remain more discreet to offer greater freedom in the design of the handle. The mechanism is easy and quick to assemble.

DK VIS TS 9 mm

🔒 🔒



Il DK anti intrusione con pulsante di sicurezza.

Sempre in 9 mm, sempre senza lavorazioni. Studiato appositamente per evitare che, forando il serramento dall'esterno, sia possibile azionare il meccanismo. TSDK non richiede lavorazioni e può essere installato anche in sostituzione a modelli precedenti. Inoltre è configurabile con tutti i modelli a catalogo.

The DK anti-intrusion model with security latch.

Still with a thickness of 9 mm, without the need for complicated installation operations. Specially designed to avoid the possibility of opening by drilling from the outside. TSDK does not require machining and can also be installed in place of previous models. It can also be coordinated with all the models in the catalogue.

Legenda / Summary

Porta / Door

- VIS** 50x7 mm
rosetta-bocchetta quadrata
square rose-escutcheon
- FINE** 50x4 mm
rosetta-bocchetta quadrata
square rose-escutcheon
- 52** 52x10 mm
rosetta-bocchetta quadrata
square rose-escutcheon
- VIS** 50x7 mm
rosetta-bocchetta tonda
round rose-escutcheon
- FINE** 50x4 mm
rosetta-bocchetta tonda
round rose-escutcheon
- 52** 52x10 mm
rosetta-bocchetta tonda
round rose-escutcheon
- B** 50x10 mm
rosetta-bocchetta tonda bombata
rounded rose-escutcheon
- R** rosetta-bocchetta speciale
special rose-escutcheon
- R** rosetta-bocchetta speciale quadrata
special square rose-escutcheon
- V** rosetta-bocchetta ovale
oval rose-escutcheon
- S** rosetta-bocchetta stretta ovale
narrow oval rose-escutcheon
- S** rosetta-bocchetta stretta rettangolare
narrow rectangular rose-escutcheon

Finestra / Window

- VIS** rosetta-bocchetta quadrata per DK VIS 9 mm
DK window handle square rose-escutcheon VIS 9 mm
- VIS** rosetta-bocchetta tonda per DK VIS 9 mm
DK window handle round rose-escutcheon VIS 9 mm
- 🔒** rosetta-bocchetta quadrata per DK VIS TS 9 mm
DK window handle square rose-escutcheon VIS TS 9 mm
- 🔒** rosetta-bocchetta tonda per DK VIS TS 9 mm
DK window handle round rose-escutcheon VIS TS 9 mm

finiture / finishes

Finiture su ottone / Brass finishes

OLV	Lucido <i>Polished</i>	FAN	Ferro anticato <i>Antique iron</i>
OS	Satinato <i>Satin</i>	ONV	Nickel lucido <i>Polished nickel</i>
OLS	Lucido - Satinato <i>Polished - Satin</i>	ORO	Placcato oro 24K <i>Gold plated 24K</i>
AB	Bronzato <i>Antique bronze</i>	OROF	Oro francese <i>French gold</i>
AF	Anticato <i>Antique finish</i>	PGS	PVD grafite satinato <i>Satin graphite PVD</i>
OGC	Bronzo satinato lucido <i>Bright satin bronze</i>	PVD-BG	PVD oro antico lucido <i>Antique bright gold PVD</i>
OGH	Bronzo satinato opaco <i>Matt satin bronze</i>	PVD-SG	PVD oro antico satinato <i>Antique satin gold PVD</i>
BSS	Bronzo scuro sfumato <i>Shaded dark bronze</i>	PVD	PVD Oro <i>Gold PVD</i>
OC	Power cromo lucido <i>Power polished chrome</i>	PVX	PVD Inox <i>Steel PVD</i>
PCS	Power cromo satinato <i>Power satin chrome</i>	OBN	Bianco <i>White</i>
OCS	Cromo satinato <i>Satin chrome</i>	ONO	Nero <i>Black</i>
CCS	Cromo - Power cromo satinato <i>Chrome - Power satin chrome</i>	V702	Marrone <i>Brown</i>
ONS	Nickel satinato <i>Satin nickel</i>		

Finiture su zama / Zamak finishes

ZC	Cromo lucido <i>Polished chrome</i>
ZCS	Cromo satinato <i>Satin chrome</i>
ZCCS	Cromo - Cromo satinato <i>Chrome - satin chrome</i>
ZNS	Nickel satinato <i>Satin nickel</i>
ZOL	Ottonato lucido <i>Polished brass color</i>
ZOS	Ottonato satinato <i>Satin brass color</i>
ZGH	Bronzo satinato opaco <i>Matt satin bronze</i>
ZOR	Placcato oro 24K <i>Gold plated 24K</i>
ZBN	Bianco <i>White</i>
ZNE	Nero <i>Black</i>

Finiture su acciaio inox / Stainless steel finishes

S304	Acciaio AISI 304 satinato <i>AISI 304 satin steel</i>
S316	Acciaio AISI 316 satinato <i>AISI 316 satin steel</i>
L316+R	AISI 316 lucido + inserto rame PVD / <i>AISI 316 polished + PVD copper insert</i>
S316+R	AISI 316 satinato + inserto rame PVD / <i>AISI 316 satin + PVD copper insert</i>
L316+N	AISI 316 lucido + inserto rame nero / <i>AISI 316 polished + copper black insert</i>
S316+N	AISI 316 satinato + inserto rame nero / <i>AISI 316 satin + copper black insert</i>

Finiture su alluminio / Aluminium finishes

ASV	Silver <i>Silver</i>
ARO	Oro satinato <i>Satin gold</i>
ABR	Bronzo <i>Bronze</i>
ABN	Bianco <i>White</i>
ANE	Nero <i>Black</i>

PVD-BG

Oro antico lucido /
Antique bright gold



PVD-BG **Oro antico lucido.**

Il colore dell'ottone ha un fascino intramontabile e viene proposto con una tonalità più calda.

Mantiene inalterato nel tempo il colore di origine, presentando ottime caratteristiche sia dal punto di vista estetico che della durabilità nel tempo.

Questi rivestimenti, testati in nebbia salina, hanno superato le 1500 ore di resistenza assicurando una garanzia di 20 anni in normali condizioni di utilizzo.

PVD-BG **Antique bright gold.**

The timeless color of brass, reinterpreted in a particularly warm, fascinating tone. The original color lasts over time, conserving its excellent characteristics in terms of looks and durability. These finishes tested in salt spray have stood up to trials of 1500 hours, and are guaranteed to last 20 years under normal conditions of use.

PVD-SG

Oro antico satinato /
Antique satin gold



PVD-SG **Oro antico satinato.**

L'ottone satinato è proposto in una nuova nuance estremamente piacevole, dal sapore antico e al contempo attuale, che ben si adatta in ambienti eleganti e moderni.

Questi rivestimenti, testati in nebbia salina, hanno superato le 1500 ore di resistenza assicurando una garanzia di 20 anni in normali condizioni di utilizzo.

PVD-SG **Antique satin gold.**

The brushed brass is offered in an extremely appealing shade, with an antique but at the same time very contemporary look that fits perfectly into elegant and modern settings.

These finishes tested in salt spray have stood up to trials of 1500 hours, and are guaranteed to last 20 years under normal conditions of use.

PGS

Grafite satinato / Satin graphite



PGS **Grafite satinato.**

Ottone con finitura PVD in grafite satinato. Una conferma per questo colore, originale e accattivante. È adatto ad ambienti moderni e di design.

Il colore grigio scuro con effetto satinato restituisce riflessi lucenti. Finitura garantita 10 anni.

PGS **Satin graphite.**

Brass with PVD finish in brushed graphite. This original, captivating color has become a true favorite, ideal for settings with an accent on modern design.

The dark gray color with a brushed effect provides glowing highlights. The finish comes with a 10 year guarantee.

ONV

Nickel lucido / Polished nickel



ONV **Nickel lucido.**

Il nickel lucido è trattato con vernice trasparente. Più caldo e intrigante del colore cromato, la sua applicazione tende ad ammorbidire anche l'oggetto più spigoloso, dandogli un tocco di raffinatezza. Finitura garantita 10 anni.

ONV **Polished nickel.**

The polished nickel, treated with transparent varnish, is warmer and more intriguing than the chrome color. Its application tends to soften the lines of even the sharpest objects, adding a touch of true refinement.

The finish comes with a 10 year guarantee.

OC

Power cromo lucido / Power polished chrome



OC

Power cromo lucido.

Processo di cromatura a spessore che arricchisce di lucentezza e morbidezza. Grazie alla particolare deposizione di composti metallici la finitura assicura elevate performance di durata rispetto alle sollecitazioni a cui è sottoposta. Finitura garantita 10 anni.

OC

Power polished chrome.

*Power polished chrome.
A thick chrome plating process that enhances gloss and smoothness. Through the use of specific metal composites, the finish provides high performance even under demanding conditions of use.
The finish comes with a 10 year guarantee.*

PCS

Power cromo satinato / Power satin chrome



PCS

Power cromo satinato.

Processo di cromatura a spessore che arricchisce di lucentezza e morbidezza. Grazie alla particolare deposizione di composti metallici la finitura assicura elevate performance di durata rispetto alle sollecitazioni a cui è sottoposta. Processo di satinatura superfine, risultato morbido e lucente. Finitura garantita 10 anni.

PCS

Power satin chrome.

*Power polished chrome.
A thick chrome plating process that enhances gloss and smoothness. Through the use of specific metal composites, the finish provides high performance even under demanding conditions of use.
Superfine brushing for a soft, lustrous surface.
The finish comes with a 10 year guarantee.*

OGH

Bronzo satinato opaco / Matt satin bronze



OGH **Bronzo satinato opaco.**

Una bronzatura e una fine graffiatura manuale, unite a una vernice opaca, contribuiscono a creare questa superficie elegante e di tendenza.

Nato come finitura di modelli classici, il bronzo satinato opaco è sempre più apprezzato anche su modelli dalle forme più decise che ne valorizzano le caratteristiche estetiche.

OGH **Matt satin bronze.**

A bronze finish with fine brushing done by hand, followed by a coat of matt varnish to generate an elegant, trend-setting surface. Created as a finish for the classic models, it is now also being used for the design handles with their more forceful forms, because it brings out their aesthetic characteristics.

ONO

Nero / Black



ONO **Nero.**

Il colore nero opaco è applicato con resistente vernice a polvere.

L'ottone è così proposto in maniera insolita e moderna, molto apprezzato dagli interior designer per la sua adattabilità ad ambienti di diverso tipo.

Della stessa famiglia, il colore bianco OBN e la nuova – molto attuale – finitura marrone V702.

ONO **Black.**

The matt black color, applied in a durable powder coating. Here brass is interpreted in an unusual modern way much appreciated by today's interior designers. Suitable for any space where classic or modern handles are used.

The same family includes the OBN white color and the new, very timely V702 brown finish.

Finiture cromate / Chrome finishes

Finiture galvaniche da cromo e nickel
per superfici lucide e satinare.

*Chrome and nickel galvanic finishes for
polished and brushed surfaces.*



OC
Power cromo lucido
Power polish chrome



PCS
Power cromo satinato
Power satin chrome



ONV
Nickel lucido
Polished nickel



ONS
Nickel satinato
Satin nickel

Finiture ultrasensibili / Ultra resistant finishes

Rivestimenti metallici sottovuoto
denominati PVD (Physical Vapor
Deposition).
Inossidabili, antigraffio e antiusura.

*Metal vacuum coatings made with the
process known as PVD (Physical Vapor
Deposition).
Stainless, scratchproof and wearproof.*



PVD-BG
PVD oro antico lucido
Antique bright gold PVD



PVD-SG
PVD oro antico satinato
Antique satin gold PVD



PGS
PVD grafite satinato
Satin graphite PVD



PVX
PVD inox
Inox PVD



PVD
PVD oro
Gold PVD

Finiture dorate / Golden finishes

Il prestigio dell'ottone reso brillante tramite spazzolature e finiture artigianali realizzate da mani esperte. Placcature di oro 24K per rendere ancora più raffinate le superfici.

The prestige of brass, honed by brushing and handmade finishing by skilled artisans. The 24K gold plating makes the surfaces even more refined.



ORO
Placcato oro 24K
Gold plated 24K



OROF
Oro francese
French gold



OLV
Lucido
Polished



OS
Satinato
Satin

Finiture bronzate / Bronze finishes

Bronzature e graffiature con verniciatura opaca. L'unicità di un materiale come l'ottone rende possibile una realizzazione molto raffinata.

Bronze coating and texturing with matt varnish. The unique character of brass in an exceptionally refined interpretation.

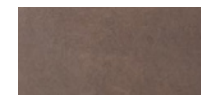

AB
Bronzato
Antique bronze



OGH
Bronzo satinato opaco
Matt satin bronze

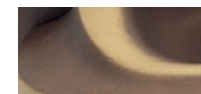

BSS
Bronzo scuro sfumato
Shaded dark bronze

Finiture anticate / Antique finishes

Finiture anticate, ottenute grazie a specifici processi di invecchiamento dell'ottone.

Antique finishes creating with special aging processes for brass.



AF
Anticato
Antique finish



FAN
Ferro anticato
Antique iron

Finiture colorate RAL / RAL colors finishes

La solidità dell'ottone proposta in diversi colori: bianco, nero, giallo, rosso, marrone, verde.

The solidity of brass offered in different colors: white, black, yellow, red, brown, green.



OBN
Bianco
White



ONO
Nero
Black



OGA
Giallo
Yellow



ORS
Rosso
Red

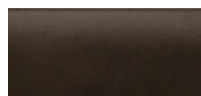

V702
Marrone
Brown

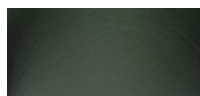

OVE
Verde
Green

resistenza al fuoco / fire resistance

Attestati di resistenza al fuoco EN 1634-2 ED. 2008

Test di resistenza al fuoco e al fumo per porte, finestre, serrature e componenti di ferramenta da costruzione.

I prodotti Dnd possono essere utilizzati per installazioni su porte e finestre che hanno ottenuto la certificazione EN 1634-2 e che hanno dimostrato di possedere la medesima resistenza al fuoco.

Attestation of fire resistance EN 1634-2 ED. 2008

Fire resistance and smoke control tests for door, shutter and openable window assemblies and elements of building hardware.

The Dnd products can be used for installation on doors and openable windows of similar type that had been tested according to EN 1634-2, and have been shown to have at least the same fire resistance.



progettisti / designers



Achille
Castiglioni,
Gianfranco
Cavaglia



Odo Fioravanti



Sandro Santantonio



Mario Padiglione



Giulio Iacchetti



Andrea Morgante



Nicola Novelletto



Studio Hot Lab



Jaime Hayon



Karim Rashid



Didier Schweizer



Mauro Ronchi



Marco Pisati



Enrico Martini



Inga Sempé

– design

maniglie
design

handles

zeppelin

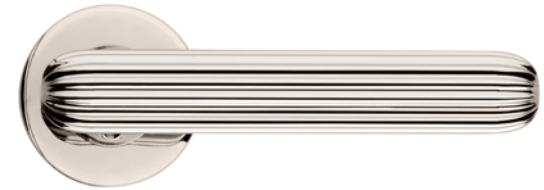

Volumi marcati e arrotondati come rimando formale - e decorativo - ai dirigibili Zeppelin dell'inizio del 1900, per una maniglia contemporanea, dalla sapiente realizzazione tecnica.

Pronounced rounded volumes as a formal - and decorative - reference to the Zeppelin airships of the early 1900s, for a contemporary handle made with great technical prowess.

zeppelin

design:
Jaime Hayon

Ottone stampato a caldo
Hot stamped brass



ONO
Nero
Black



OVE
Verde
Green



ONV
Nickel lucido
Polished nickel



PVD-BG
PVD oro antico lucido
Antique bright gold PVD



ZP12
ONV

044-

dnd 2018/2019

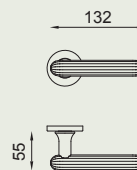

VIS ZP12

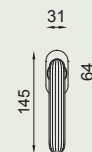

VIS ZP22V

🔒 ZP22TS

045

madeleine

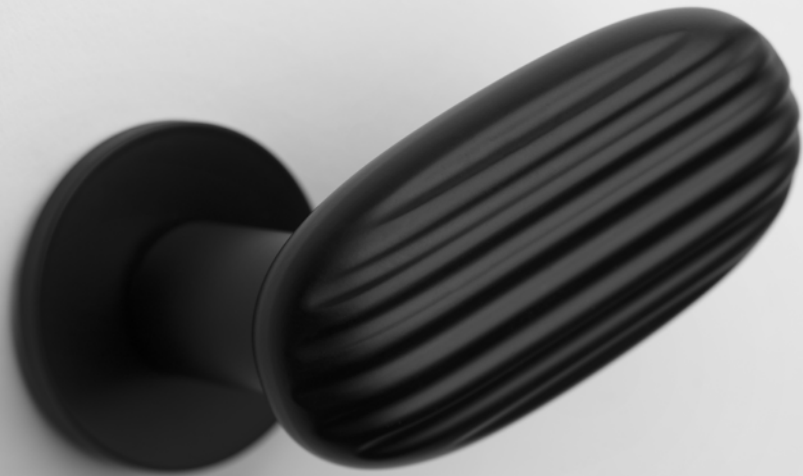

Un omaggio alla dolce
madeleine d'oltralpe
in una piccola maniglia
decorata che ne
riprende la forma
a conchiglia.

*A tribute to the
famous madeleine
cakes from beyond
the Alps, in a small
decorated handle
that replicates their
seashell form.*

madeleine

design:
Inga Sempé

Ottone stampato a caldo
Hot stamped brass



ONO
Nero
Black



ONV
Nickel lucido
Polished nickel



PVD-BG
PVD oro antico lucido
Antique bright gold PVD



MA40
PVD-BG

048-

dnd 2018/2019

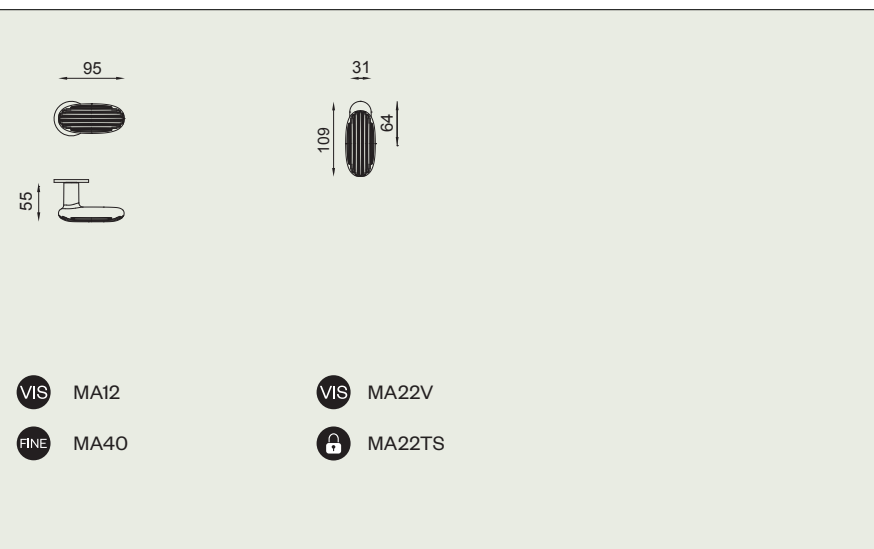

049

boole

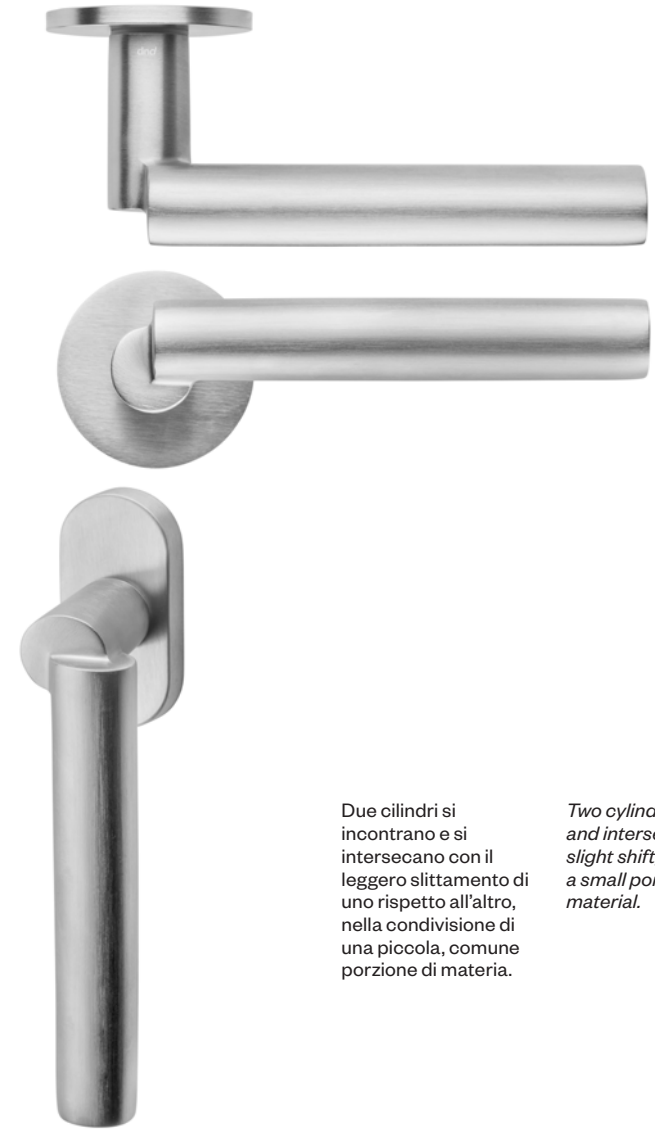

Due cilindri si incontrano e si intersecano con il leggero slittamento di uno rispetto all'altro, nella condivisione di una piccola, comune porzione di materia.

Two cylinders meet and intersect with a slight shift, sharing a small portion of material.

boole

design:
Odo Fioravanti

Ottone stampato a caldo
Hot stamped brass



OC
Power cromo lucido
Power polished chrome



PCS
Power cromo satinato
Power satin chrome



ONO
Nero
Black



BE40
OC

052-

dnd 2018/2019

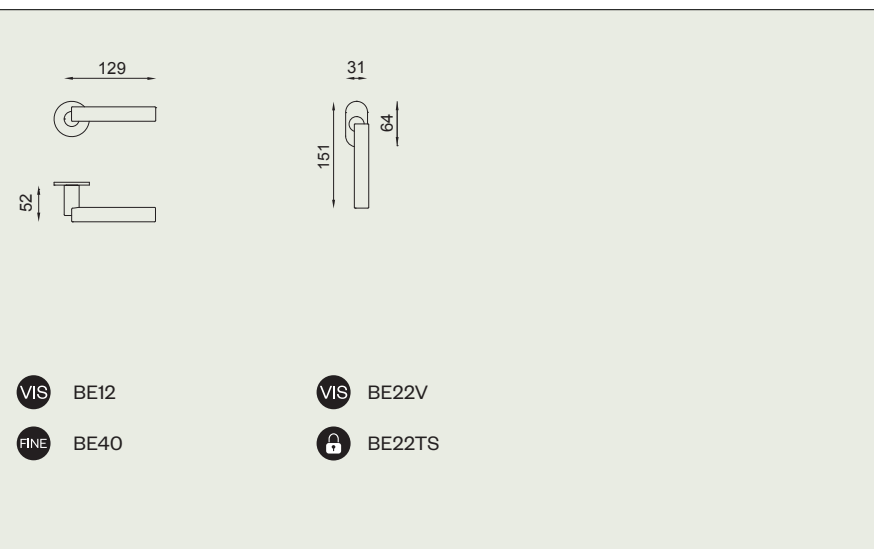

053

safety



Un nastro di metallo
si fa maniglia
ripiegandosi sul finale,
per assicurare una
buona e sicura presa.

*A metal ribbon
becomes a handle,
bending at its end
to provide a sure,
safe grip.*

safety

design:
Enrico Martini

Ottone stampato a caldo
Hot stamped brass



OC
Power cromo lucido
Power polished chrome



PCS
Power cromo satinato
Power satin chrome



ONO
Nero
Black



SA40
PCS

056-

dnd 2018/2019

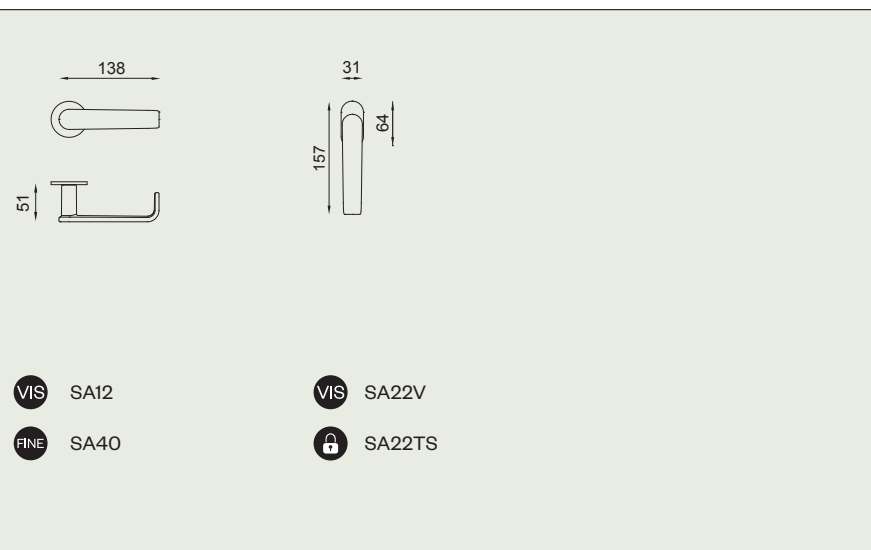

057

ginkgo



Una forma di ispirazione naturale, quale la bellissima foglia del Ginkgo, si fa struttura e decoro per una maniglia che nasce in due diverse versioni.

A form based on nature, the special, unique shape of a Ginkgo leaf, becomes the structure and decoration of a handle that is made in two different versions.

ginkgo

design:
Giulio Iacchetti



GK40
PCS

060-

Ottone stampato a caldo
Hot stamped brass



OC
Power cromo lucido
Power polished chrome



PCS
Power cromo satinato
Power satin chrome



ONV
Nickel lucido
Polished nickel



PGS
PVD grafite satinato
Satin graphite PVD



PVD-BG
PVD oro antico lucido
Antique bright gold PVD



PVD-SG
PVD oro antico satinato
Antique satin gold PVD

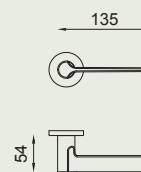

**Good Design Awards
2017**

VIS GK12

VIS GK22V

FINE GK40

LOCK GK22TS

dnd 2018/2019

061

ginkgo biloba

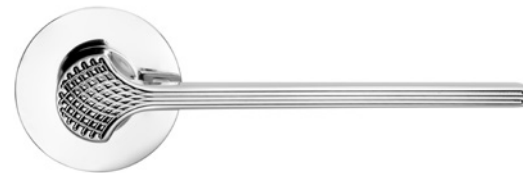

Ginkgo Biloba, la versione della maniglia Ginkgo con l'incisione in superficie, è un ulteriore rimando metaforico alle venature della foglia.

Ginkgo Biloba, the version of the Ginkgo handle with the decorative surface engraving, is a further metaphorical reminder of the veins of the leaf.

ginkgo biloba

design:
Giulio Iacchetti



GB40
OC

064-

Ottone stampato a caldo
Hot stamped brass



OC
Power cromo lucido
Power polished chrome



PCS
Power cromo satinato
Power satin chrome



ONV
Nickel lucido
Polished nickel



PGS
PVD grafite satinato
Satin graphite PVD



PVD-BG
PVD oro antico lucido
Antique bright gold PVD



PVD-SG
PVD oro antico satinato
Antique satin gold PVD

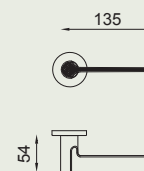

**Good Design Awards
2017**

VIS GB12

VIS GB22V

FINE GB40

LOCK GB22TS

dnd 2018/2019

065

timeless

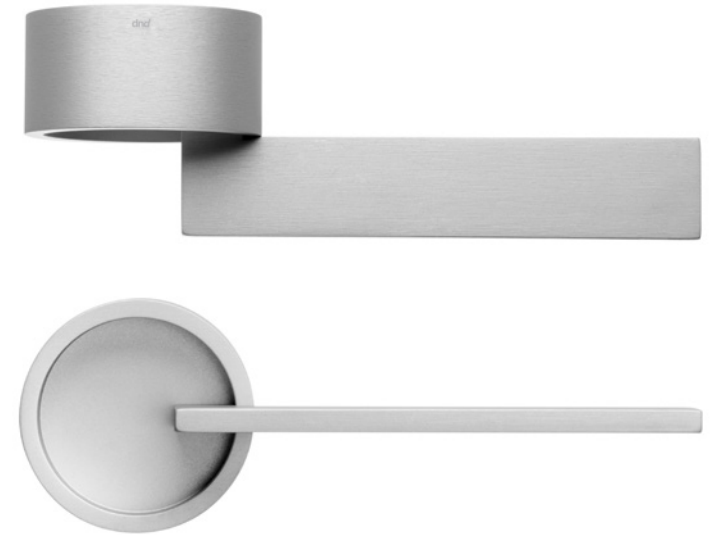

Due segni grafici
essenziali, una linea
e un cerchio che
si intersecano in
maniera centrale e
simmetrica.

*Two essential graphic
signs, a line and
a circle that intersect
in a central and
symmetrical way.*

timeless

design:
Marco Pisati

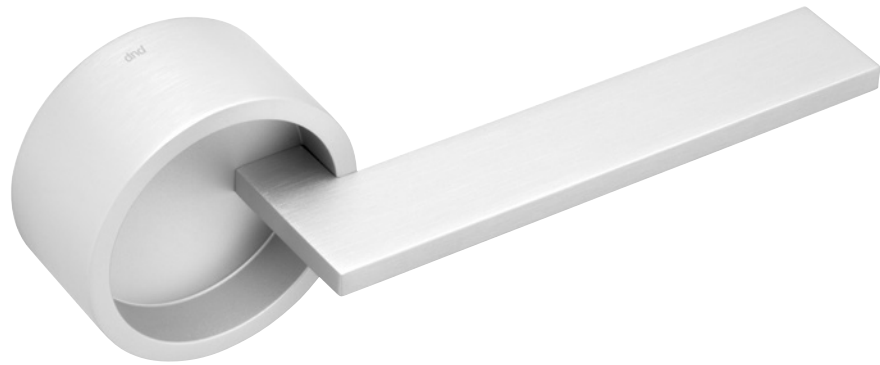

TL01
ASV

068-

dnd 2018/2019

Alluminio
Aluminium



ASV
Silver
Silver



ARO
Oro satinato
Satin gold



ABR
Bronzo
Bronze



ABN
Bianco
White



ANE
Nero
Black

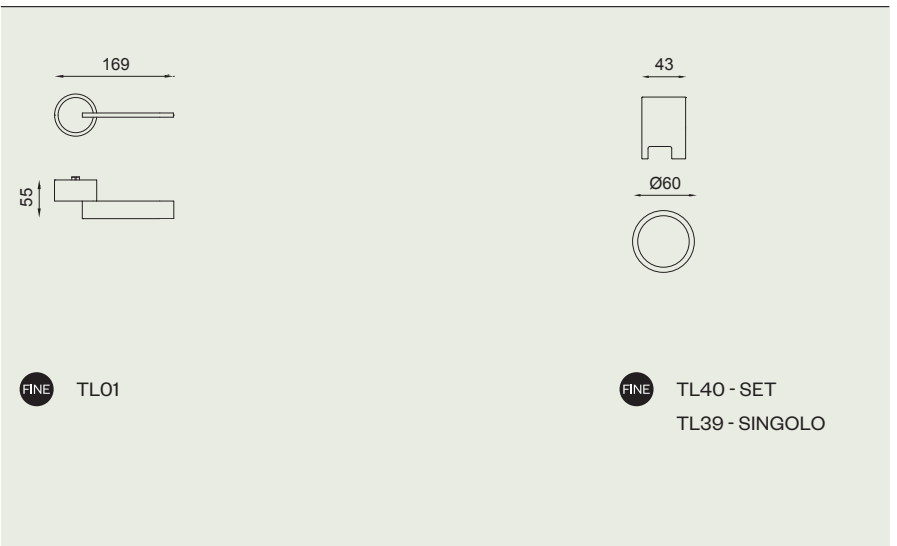

069

isabella



Un cilindro e lievi
modanature, tra forme
classiche e volumi
moderni.

*A cylinder and slight
moldings, between
classical forms and
modern volumes.*

isabella

design:
Marco Pisati

Ottone stampato a caldo
Hot stamped brass



OGH
Bronzo satinato opaco
Matt satin bronze



OC
Power cromo lucido
Power polished chrome



ONV
Nickel lucido
Polished nickel



PGS
PVD grafite satinato
Satin graphite PVD



PVD-BG
PVD oro antico lucido
Antique bright gold PVD



PVD-SG
PVD oro antico satinato
Antique satin gold PVD



IS13
OC

072-

dnd 2018/2019

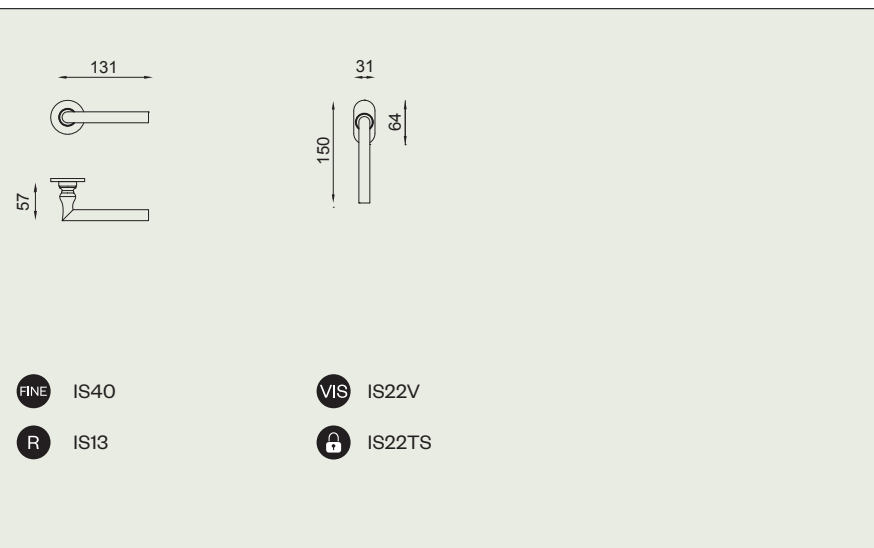

073

lucrezia



Rimandi rinascimentali nel bel modellato dello stelo, a cui si aggiunge il disegno dell'impugnatura: una forma rettangolare alleggerita da un'elegante modanatura a caratterizzare il bordo.

Renaissance references in the fine shaping of the stem, joined by the design of the grip: a rectangular form lightened by elegant shaped borders.

lucrezia

design:
Marco Pisati

Ottone forgiato
Forged brass



OLV
Lucido
Polished



OGH
Bronzo satinato opaco
Matt satin bronze



ONV
Nickel lucido
Polished nickel



PGS*
PVD grafite satinato
Satin graphite PVD



* su ordinazione / on demand

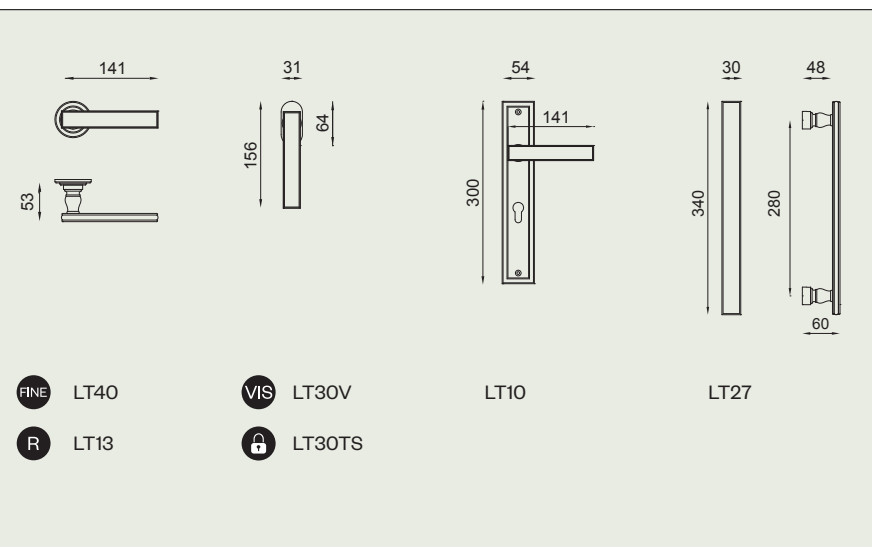

LT13
OLV

076-

dnd 2018/2019

077

lucrezia 02

design:
Marco Pisati



LT41
ONV

078-

Ottone forgiato
Forged brass



OLV
Lucido
Polished



OGH
Bronzo satinato opaco
Matt satin bronze



ONV
Nickel lucido
Polished nickel



PGS*
PVD grafite satinato
Satin graphite PVD

*** su ordinazione / on demand**

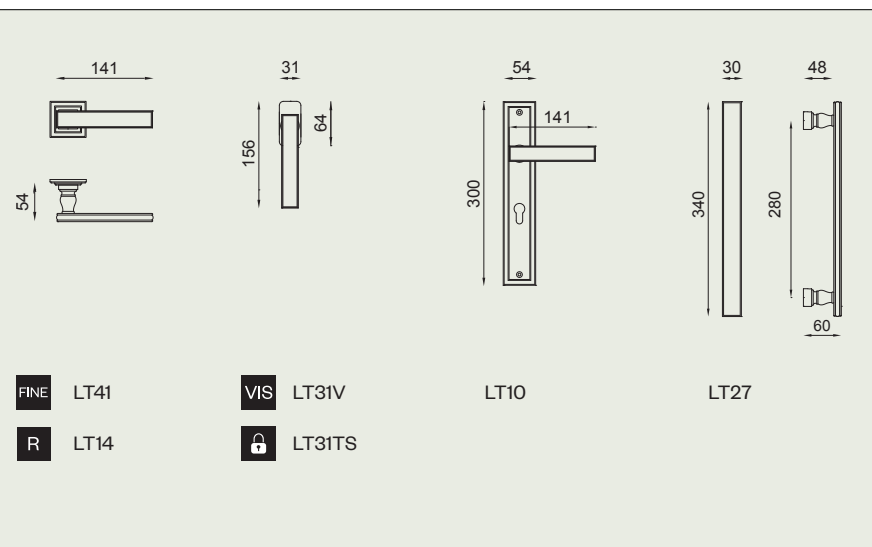

079

C-1918



Una maniglia - e una serie - d'autore caratterizzata dalla sapiente unione di acciaio e rame. Un progetto inedito, riscoperto e prodotto da Dnd con grande orgoglio.

A signature handle - and series - based on the felicitous combination of steel and copper. An original project, rediscovered and produced with great pride by Dnd.

C-1918

design:
Achille Castiglioni
Gianfranco Cavaglia

Acciaio inox AISI 316 + rame
AISI Stainless steel 316 + copper



S316 + R
AISI 316 satinato
+ inserto rame PVD
AISI 316 satin
+ *PVD copper insert*

L316 + R
AISI 316 lucido
+ inserto rame PVD
AISI 316 polished
+ *PVD copper insert*



S316 + N
AISI 316 satinato
+ inserto rame nero
AISI 316 satin
+ *copper black insert*

L316 + N
AISI 316 lucido
+ inserto rame nero
AISI 316 polished
+ *copper black insert*



CC12
L316 + R

082-

dnd 2018/2019

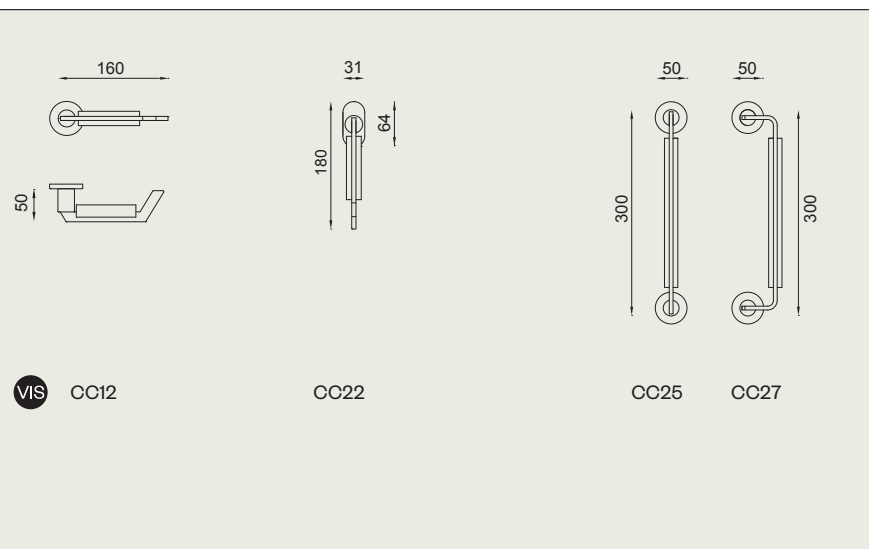

083

intake



Disegnata per il Museo Casa Enzo Ferrari di Modena, solida nella materia e plastica nella forma, è un omaggio al car design più attento.

Designed for the Enzo Ferrari Museum in Modena, solid in terms of material, sculptural in terms of form, in a tribute to the finest automotive design.

intake

design:
Andrea Morgante

Ottone stampato a caldo
Hot stamped brass



OC
Power cromo lucido
Power polished chrome

OBN
Bianco
White

ONO
Nero
Black

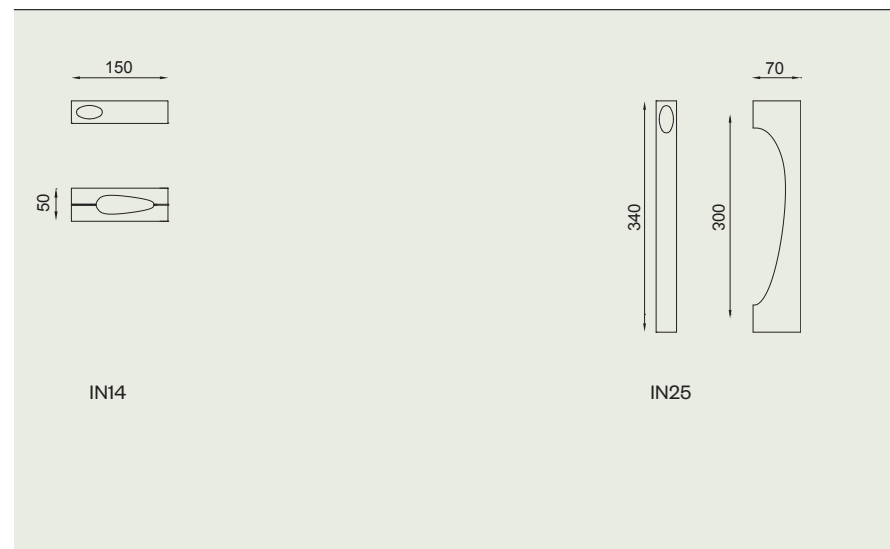

IN14
OBN

086-

dnd 2018/2019

087

luxury

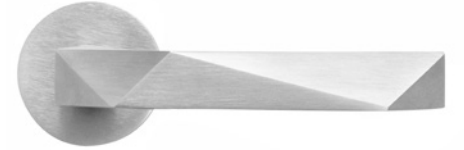
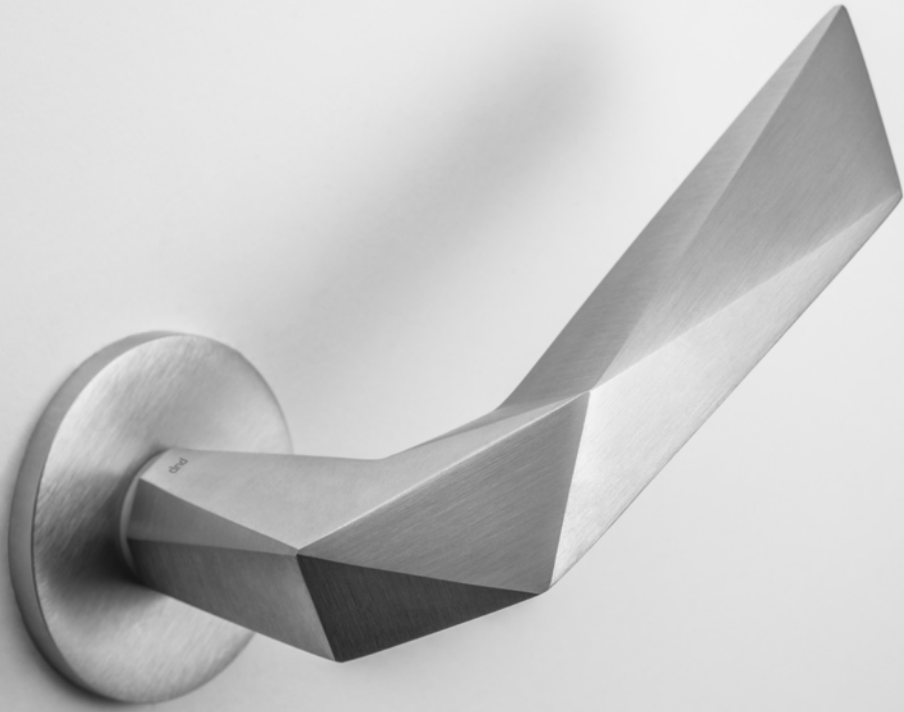

Geometrie sfaccettate e tagli netti nella materia rimandano a celebri episodi dell'architettura contemporanea.

Faceted geometry and clean cuts in the material evoke famous episodes of contemporary architecture.

luxury

design:
Mauro Ronchi

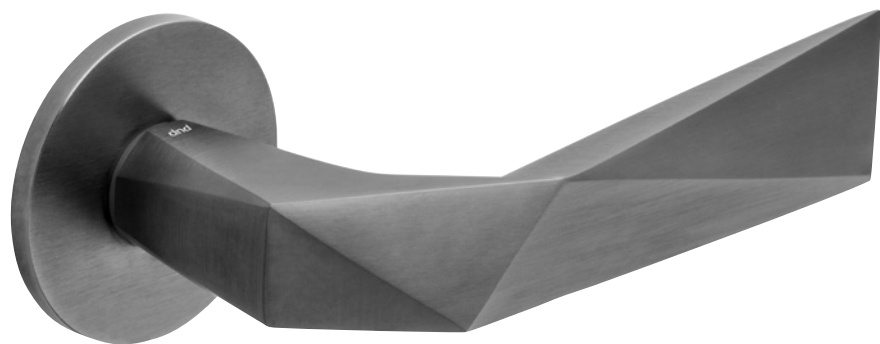

LU40
PGS

090-

Ottone stampato a caldo
Hot stamped brass



OGH
Bronzo satinato opaco
Matt satin bronze



OC
Power cromo lucido
Power polished chrome



PCS
Power cromo satinato
Power satin chrome



PGS*
PVD grafite satinato
Satin graphite PVD



PVD-BG*
PVD oro antico lucido
Antique bright gold PVD



PVD-SG*
PVD oro antico satinato
Antique satin gold PVD

* **su ordinazione / on demand**

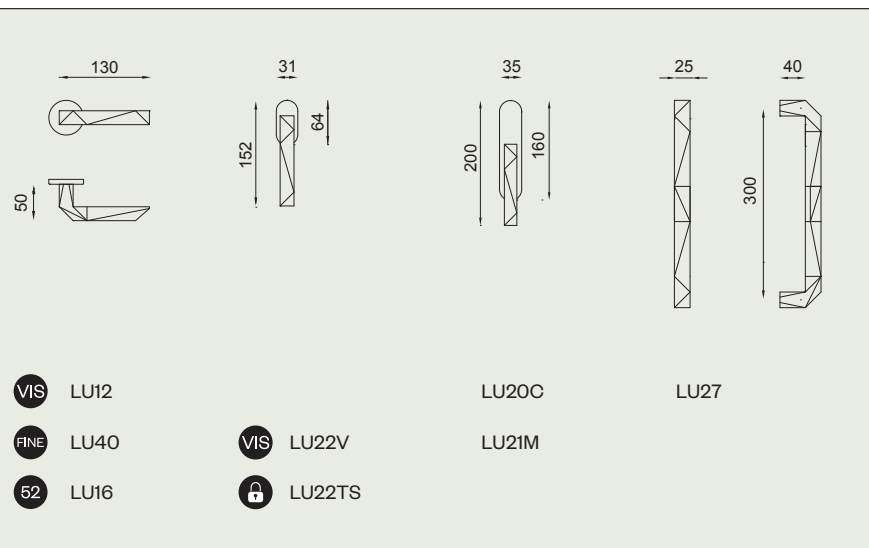

091

dnd 2018/2019

luxury 02

design:
Mauro Ronchi

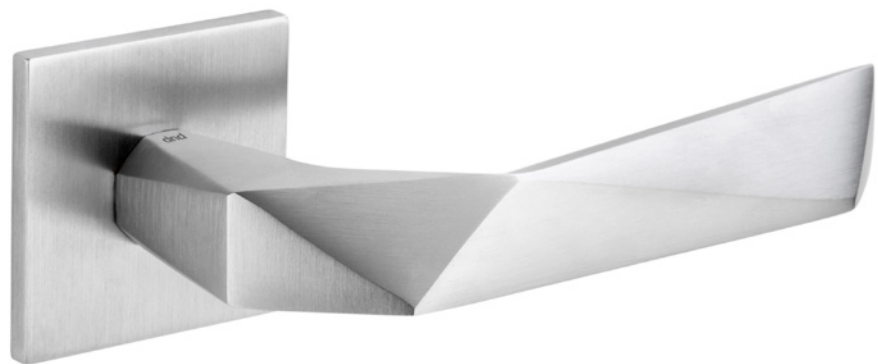

LU41
PCS

Ottone stampato a caldo
Hot stamped brass



OGH
Bronzo satinato opaco
Matt satin bronze



OC
Power cromo lucido
Power polished chrome



PCS
Power cromo satinato
Power satin chrome



PGS*
PVD grafite satinato
Satin graphite PVD



PVD-BG*
PVD oro antico lucido
Antique bright gold PVD



PVD-SG*
PVD oro antico satinato
Antique satin gold PVD

* **su ordinazione / on demand**

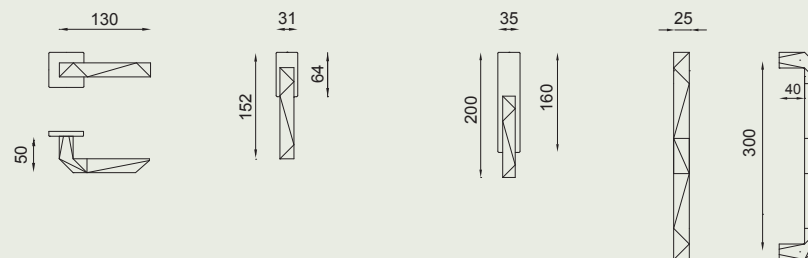

VIS	LU14	LU25	LU23C	LU27
FINE	LU41	VIS LU25V	LU24M	
52	LU18	52 LU25TS		

aretè



Un gioco di vuoti e pieni in una superficie netta e squadrata, alleggerita da piccoli trafori triangolari che si fanno decoro.

A game of openness and fullness in a precise squared surface, lightened by small triangular cutouts for a decorative touch.

aretè

design:
Mauro Ronchi

Ottone forgiato
Forged brass



AB
Bronzato
Antique bronze



OGH
Bronzo satinato opaco
Matt satin bronze



OC
Power cromo lucido
Power polished chrome



PCS
Power cromo satinato
Power satin chrome



PGS*
PVD grafite satinato
Satin graphite PVD



PVX*
PVD inox
Steel PVD

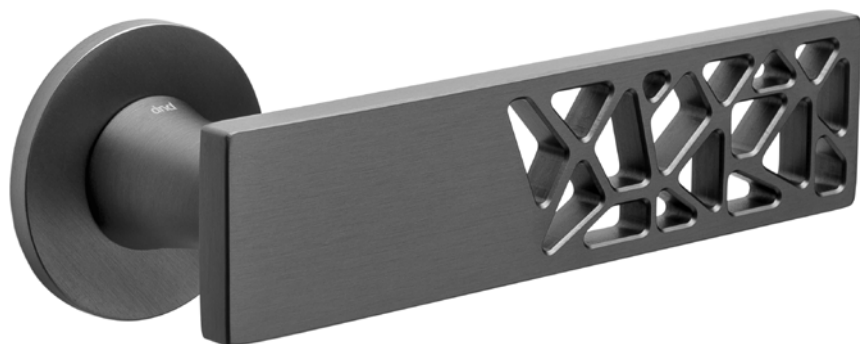

* **su ordinazione / on demand**

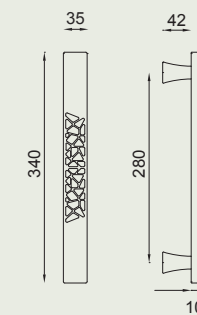
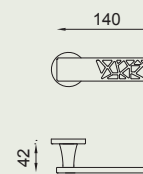

VIS AT12

VIS AT22V

AT27

FINE AT40

LOCK AT22TS

52 AT16

AT40
PGS

096-

dnd 2018/2019

097

aretè 02

design:
Mauro Ronchi



AT41
OC

Ottone forgiato
Forged brass



AB
Bronzato
Antique bronze



OGH
Bronzo satinato opaco
Matt satin bronze



OC
Power cromo lucido
Power polished chrome



PCS
Power cromo satinato
Power satin chrome



PGS*
PVD grafite satinato
Satin graphite PVD



PVX*
PVD inox
Steel PVD

* **su ordinazione / on demand**

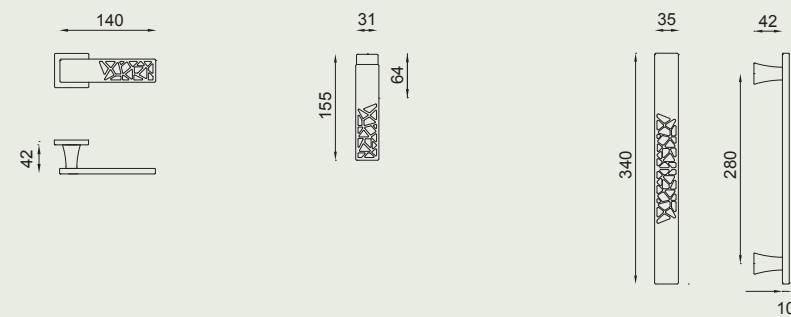

VIS AT14

AT25

AT27

FINE AT41

VIS AT25V

52 AT18

🔒 AT25TS

aretè L



Il nitore di una
geometria classica
dal sapore
contemporaneo: una
maniglia che parla di
sostanzata semplicità.

*The clarity of classical
geometry with a
contemporary mood:
a handle that speaks
of sophisticated
simplicity.*

aretè L

design:
Mauro Ronchi

Ottone forgiato
Forged brass



AB
Bronzato
Antique bronze



OGH
Bronzo satinato opaco
Matt satin bronze



OC
Power cromo lucido
Power polished chrome



PCS
Power cromo satinato
Power satin chrome



PGS*
PVD grafite satinato
Satin graphite PVD



PVX*
PVD inox
Steel PVD



* **su ordinazione / on demand**

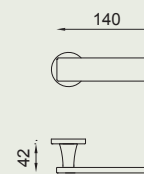

VIS AL12

FINE AL40

52 AL16

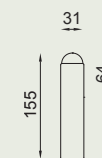

VIS AL22V

LOCK AL22TS

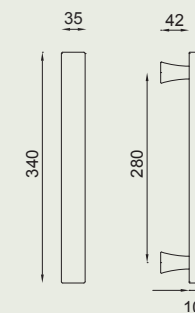

AL27

AL12
OGH

aretè L 02

design:
Mauro Ronchi

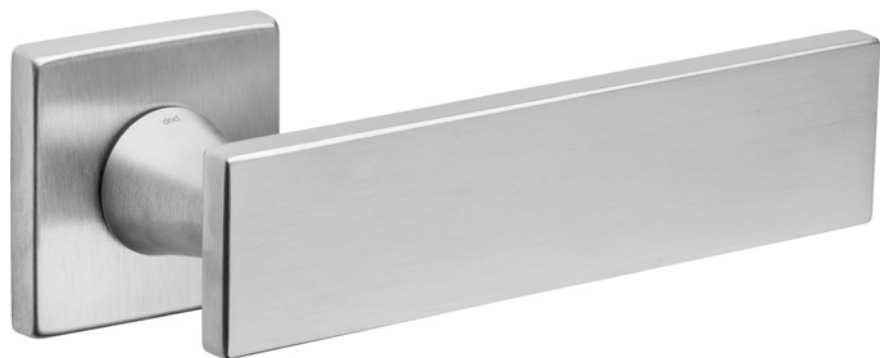

AL14
PCS

Ottone forgiato
Forged brass



AB
Bronzato
Antique bronze



OGH
Bronzo satinato opaco
Matt satin bronze



OC
Power cromo lucido
Power polished chrome



PCS
Power cromo satinato
Power satin chrome



PGS*
PVD grafite satinato
Satin graphite PVD



PVX*
PVD inox
Steel PVD

* **su ordinazione / on demand**

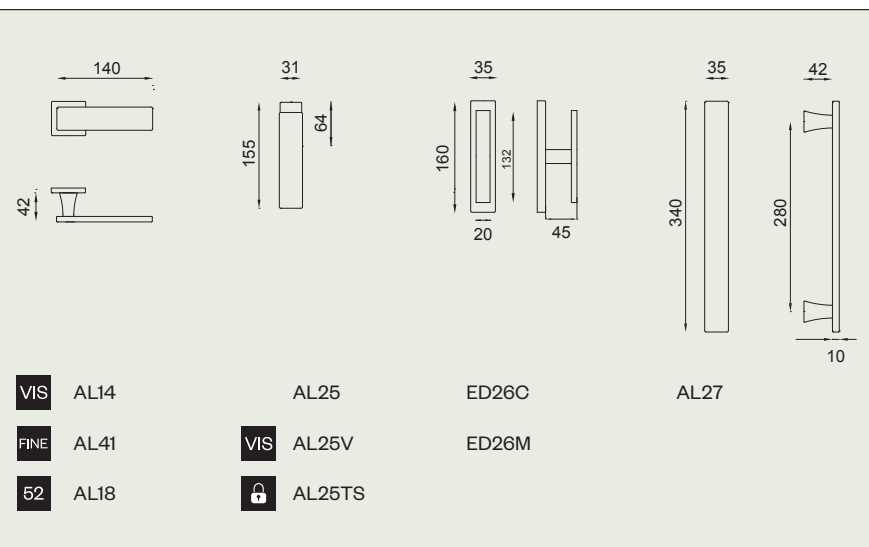

cloe

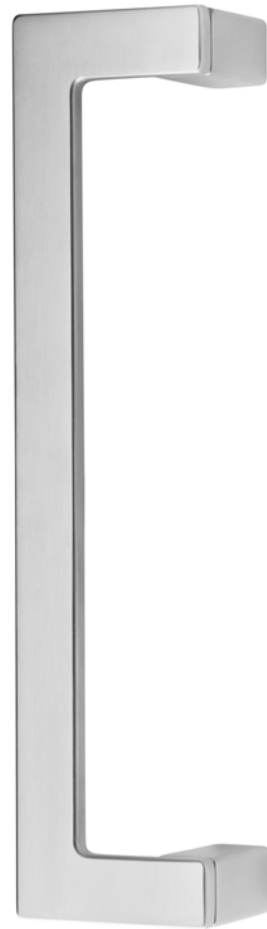

Un triangolo scolpito e rigoroso, geometrie nitide per una maniglia dedicata ad ambienti minimali ed essenziali.

A rigorously sculpted triangle, a clear geometric form in a handle designed for essential, minimal spaces.

cloe

design: Dnd
technical division



CL40
PGS

Ottone stampato a caldo
Hot stamped brass



OC
Power cromo lucido
Power polished chrome



PCS
Power cromo satinato
Power satin chrome



PGS *
PVD grafite satinato
Satin graphite PVD



PVD-BG *
PVD oro antico lucido
Antique bright gold PVD



PVD-SG *
PVD oro antico satinato
Antique satin gold PVD

*** su ordinazione / on demand**

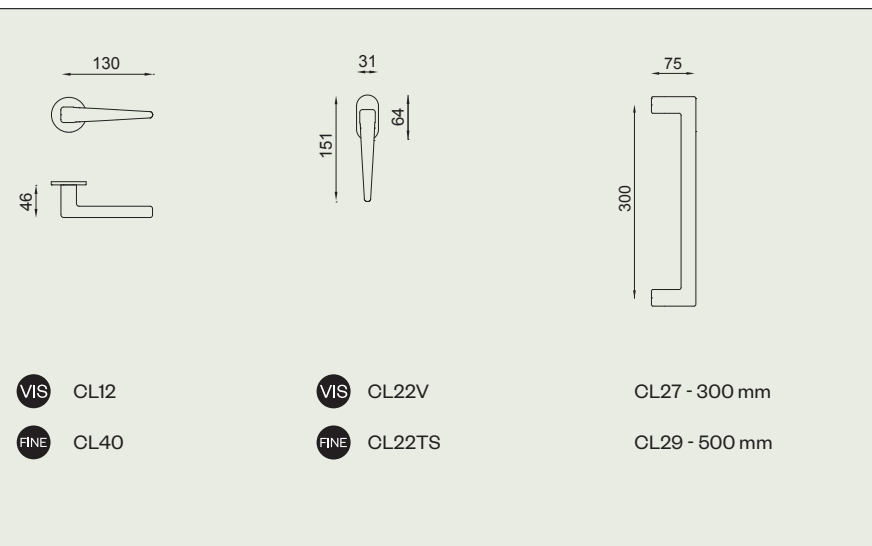

cloe 02

design: Dnd
technical division



CL41
OC

Ottone stampato a caldo
Hot stamped brass



OC
Power cromo lucido
Power polished chrome



PCS
Power cromo satinato
Power satin chrome



PGS *
PVD grafite satinato
Satin graphite PVD



PVD-BG *
PVD oro antico lucido
Antique bright gold PVD



PVD-SG *
PVD oro antico satinato
Antique satin gold PVD

*** su ordinazione / on demand**

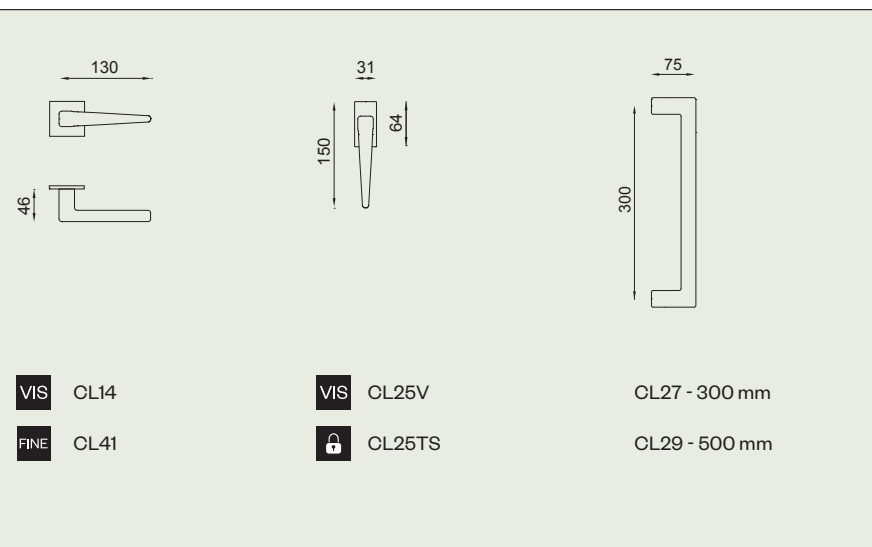

change

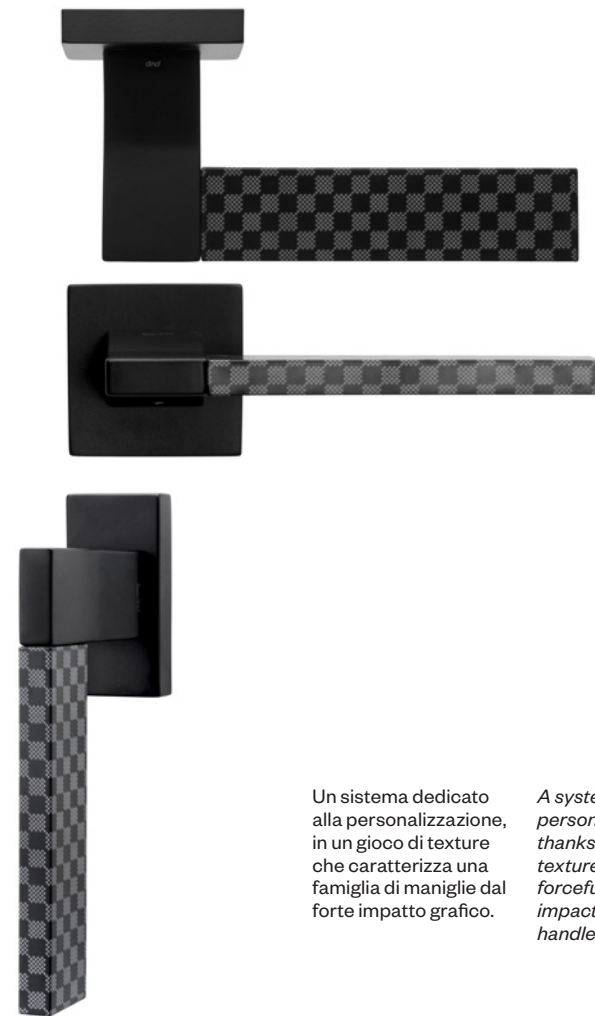

Un sistema dedicato
alla personalizzazione,
in un gioco di texture
che caratterizza una
famiglia di maniglie dal
forte impatto grafico.

*A system for
personalization,
thanks to a game of
textures that bring
forceful graphic
impact to a family of
handles.*



CH18
OC + INS 06

Ottone stampato a caldo
Hot stamped brass



OC + INS 06
Power cromo lucido
Power polished chrome



OC + INS 14
Power cromo lucido
Power polished chrome



OC + INS 03
Power cromo lucido
Power polished chrome



ONO + INS 12
Nero
Black



ONO + INS 03
Nero
Black



OBN + INS 07
Bianco
White

138

57

31

157

64

INS

- 03
- 06
- 07
- 10
- 12
- 14

VIS CH14 CH25

52 CH18 **VIS** CH25V

🔒 CH25TS

change B 02

design:
Sandro Santantonio

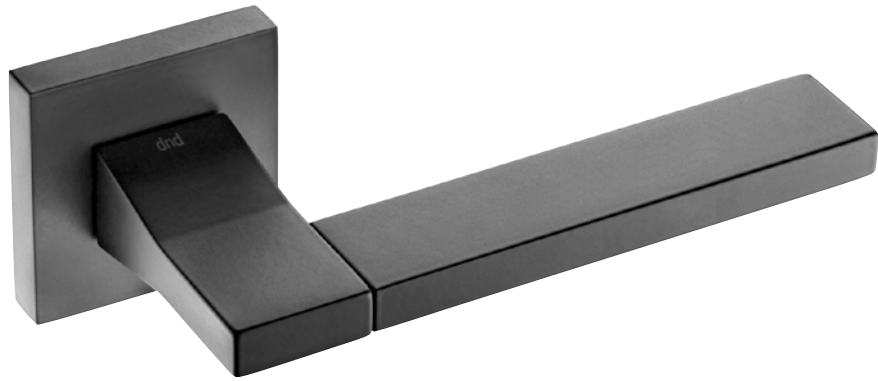

CB18
ONO

dnd 2018/2019

Ottone stampato a caldo
Hot stamped brass



CCS
Cromo - Power cromo satinato
Chrome - Power satin chrome



OBN
Bianco
White



ONO
Nero
Black



V702
Marrone
Brown

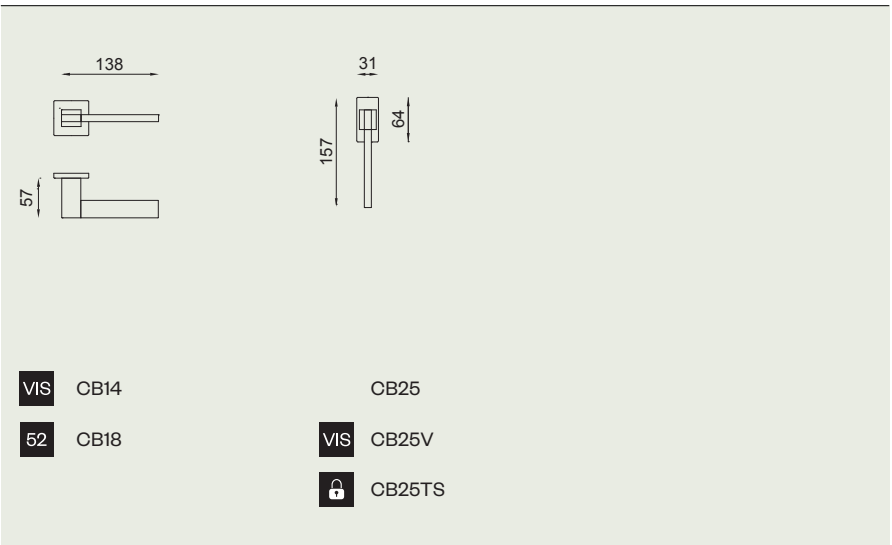

117

116-

edra 02

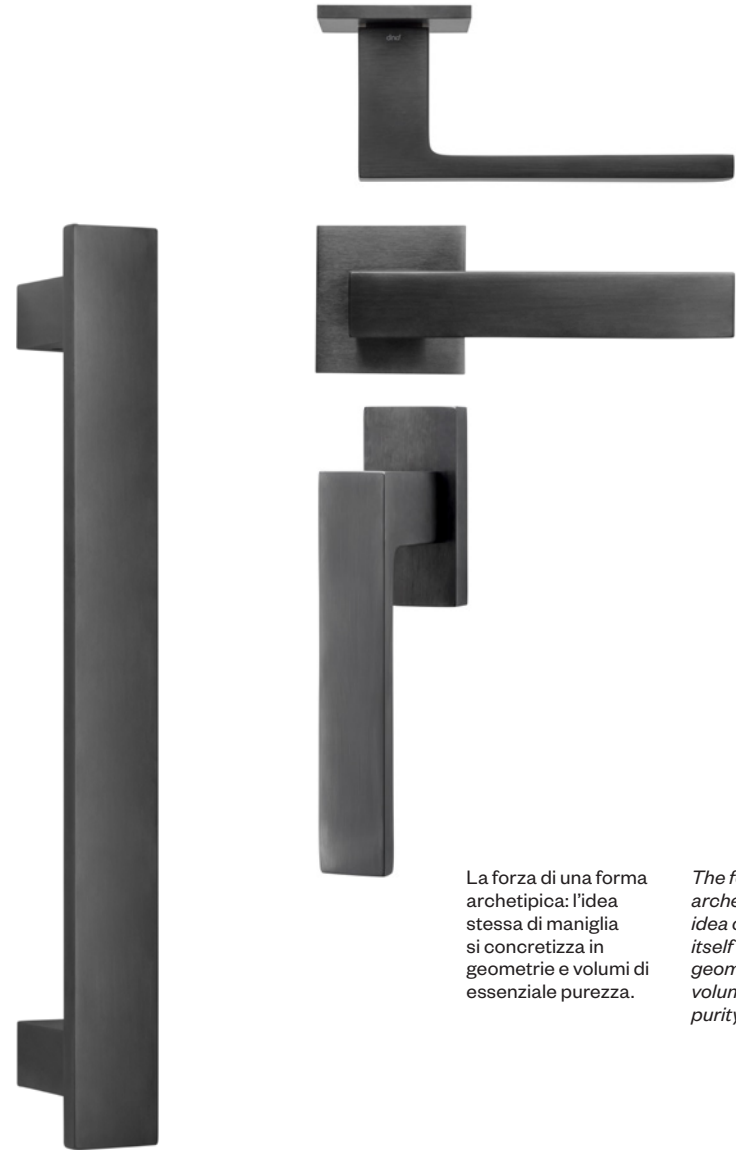

La forza di una forma
archetipica: l'idea
stessa di maniglia
si concretizza in
geometrie e volumi di
essenziale purezza.

*The force of
archetypal form: the
idea of the handle
itself embodied by
geometric lines and
volumes of essential
purity.*

edra 02

design:
Mauro Ronchi

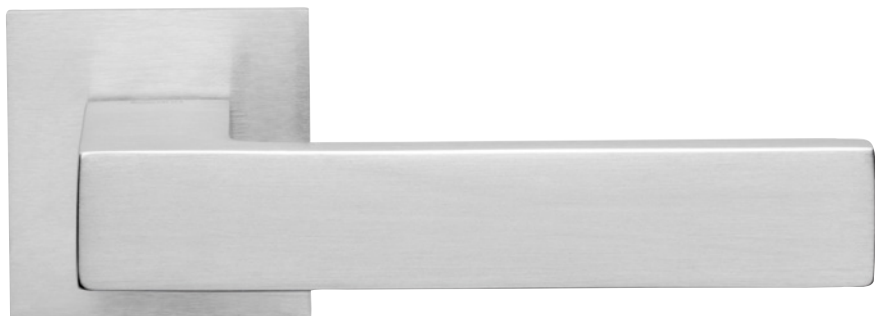

ED41
PCS

120-

Ottone stampato a caldo
Hot stamped brass



OGH
Bronzo satinato opaco
Matt satin bronze



OC
Power cromo lucido
Power polished chrome



PCS
Power cromo satinato
Power satin chrome



ONO
Nero
Black



ONS*
Nickel satinato
Satin nickel

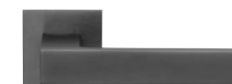

PGS*
PVD grafite satinato
Satin graphite PVD



PVX*
PVD inox
Steel PVD



CCS*
Cromo - Power cromo satinato
Chrome - Power satin chrome

* su ordinazione / on demand

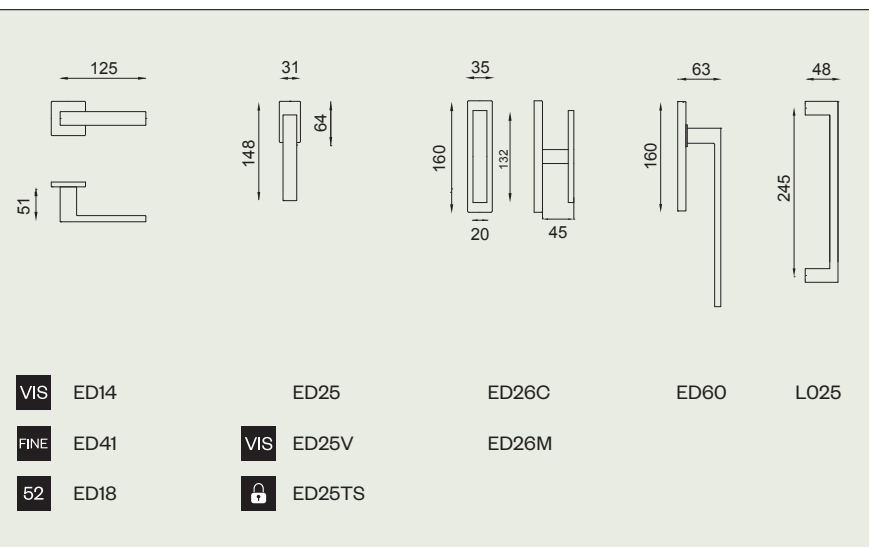

VIS	ED14	ED25	ED26C	ED60	L025
FINE	ED41	VIS	ED25V	ED26M	
52	ED18	52	ED25TS		

dnd 2018/2019

121

fluke



Una forma dinamica che nasce dall'incontro di due volumi troncoconici contrapposti: il segno forte di un design riconoscibile e riconosciuto.

A dynamic form that arises from the meeting of two opposing cones: the vivid impact of a recognizable design.

fluke

design:
Karim Rashid



FK14
PCS

Ottone stampato a caldo
Hot stamped brass



OC
Power cromo lucido
Power polished chrome



PCS
Power cromo satinato
Power satin chrome



fluke 02 - OC
Power cromo lucido
Power polished chrome



fluke 02 - PCS
Power cromo satinato
Power satin chrome

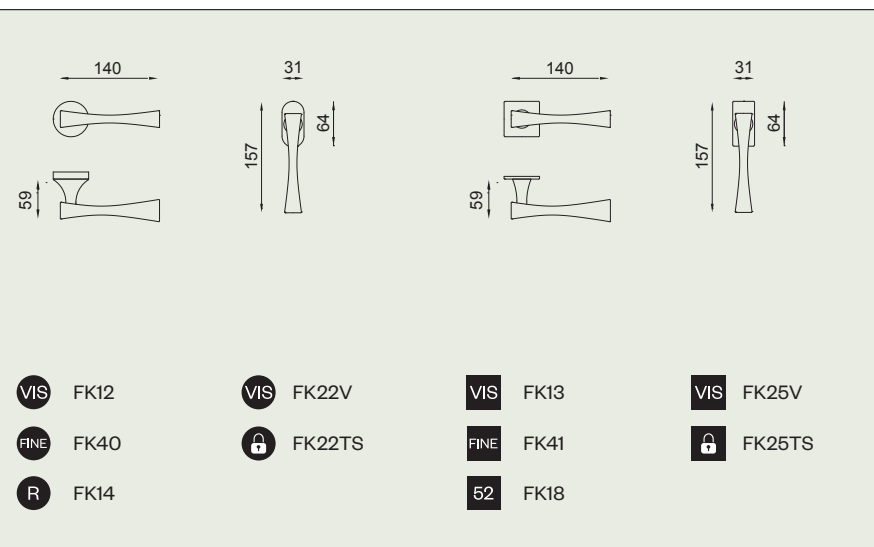

luce



La maniglia come fatto scultoreo, dove la luce evidenzia morbidezze e taglia i volumi in modo netto per restituirci l'idea stessa di un concetto plastico fuori dal tempo.

The handle as sculpture, where light brings out softness and volumes with clarity, conveying the idea of a timelessly shaped object.

luce

design: Dnd
technical division



LC12
ZC

Zama
Zamak



ZC
Cromo lucido
Polished chrome



ZCS
Cromo satinato
Satin chrome



ZGH
Bronzo satinato opaco
Matt satin bronze



ZNS
Nickel satinato
Satin nickel



ZOR
Placcato oro 24 k
Gold plated 24 k



ZNE
Nero
Black

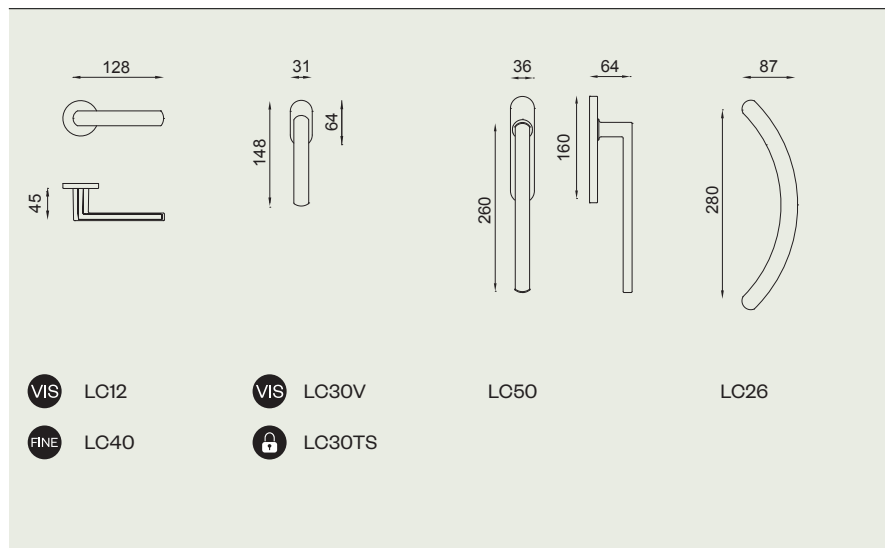

luce 02

design: Dnd
technical division



LC14
ZCS

Zama
Zamak



ZC
Cromo lucido
Polished chrome



ZCS
Cromo satinato
Satin chrome



ZGH
Bronzo satinato opaco
Matt satin bronze



ZNS
Nickel satinato
Satin nickel



ZOR
Placcato oro 24 k
Gold plated 24 k



ZNE
Nero
Black

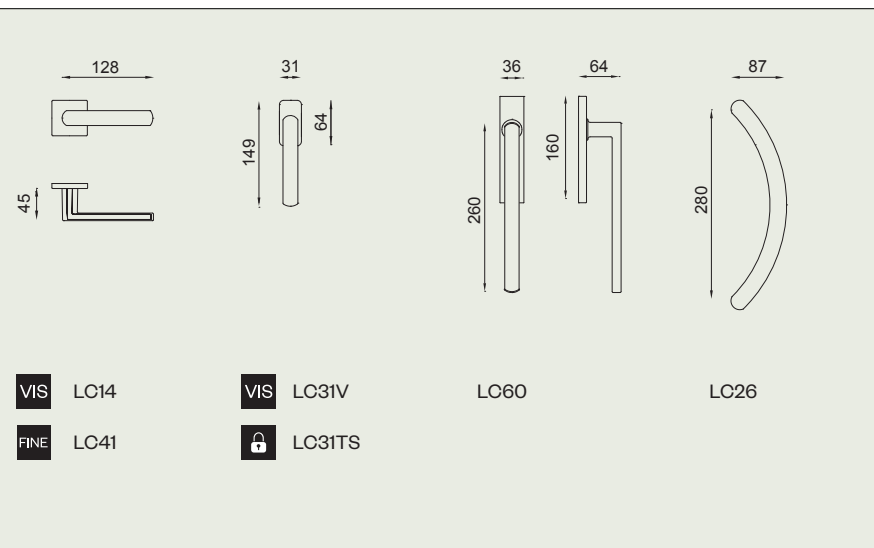

esa due



L'accostamento
di due diversi
materiali in un gioco
di sintesi formale e
compositiva.

*The combination of
two different materials
in a game of formal
and compositional
synthesis.*

esa due

design: Dnd
technical division

Alluminio e zama
Aluminium and zamak



CCS
Cromo - Power cromo satinato
Chrome - Power satin chrome

CBI
Cromo - bianco
Chrome - white

CNE
Cromo - nero
Chrome - Black

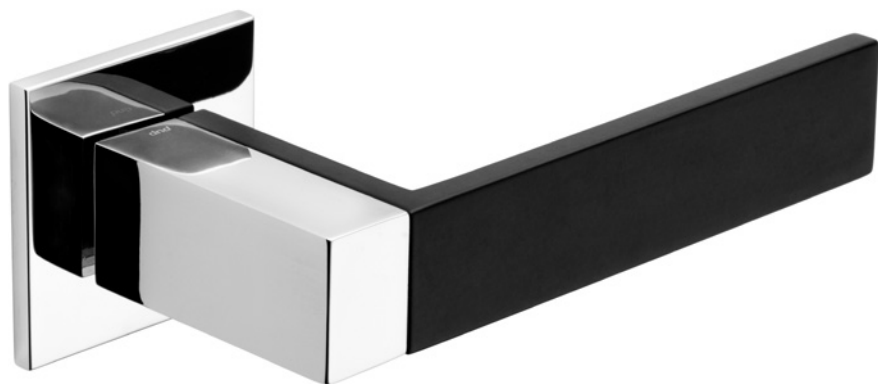

EU41
CNE

134-

dnd 2018/2019

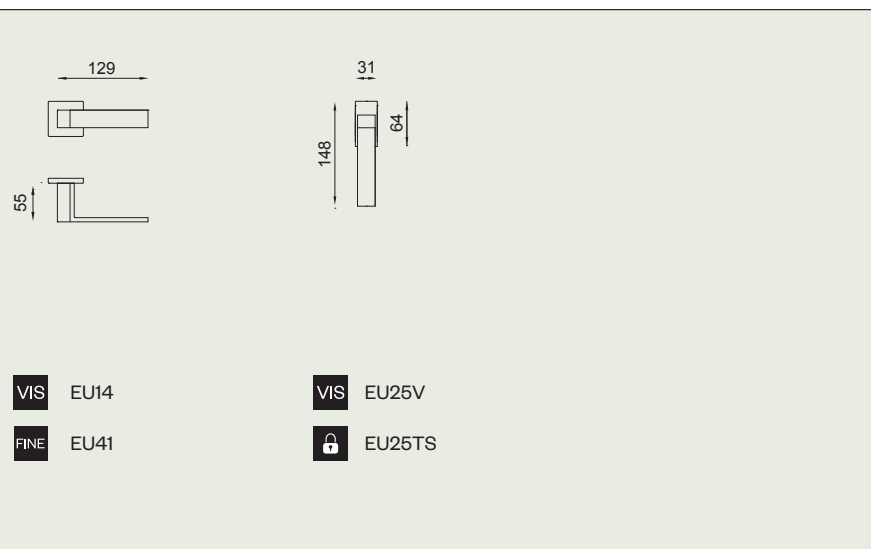

135

design:
Mauro Ronchi

Alluminio e zama
Aluminium and zamak



CCS
Cromo - Power cromo satinato
Chrome - Power satin chrome



CBI
Cromo - bianco
Chrome - white



CNE
Cromo - nero
Chrome - Black



ES14
CBI

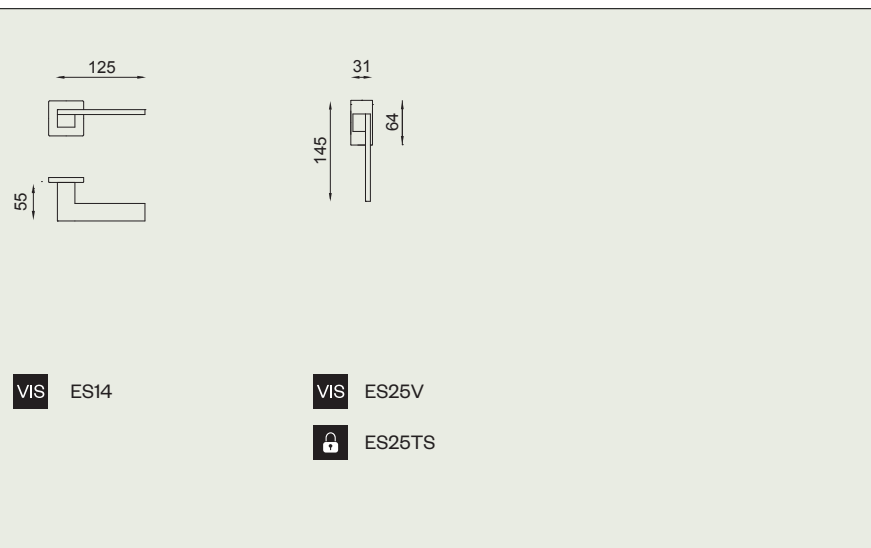

holly

design: Dnd
technical division



H014
ZC

138-

Zama
Zamak



ZC
Cromo lucido
Polished chrome



ZCS
Cromo satinato
Satin chrome



ZNE
Nero
Black



ZBN
Bianco
White

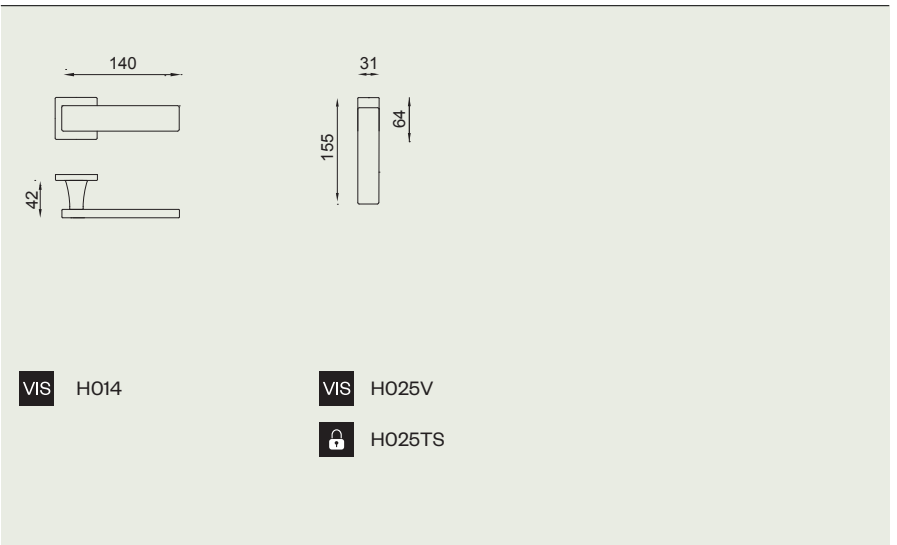

139

minima

design: Dnd
technical division



MN12
ZONE

140-

Zama
Zamak



ZCCS
Cromo lucido + cromo satinato
Polished chrome + satin chrome



ZCBI
Cromo lucido + bianco
Polished chrome + white



ZCNE
Cromo lucido + nero
Polished chrome + black

VIS MN12

VIS MN22V

🔒 MN22TS

141

chop

design:
Didier Schweizer

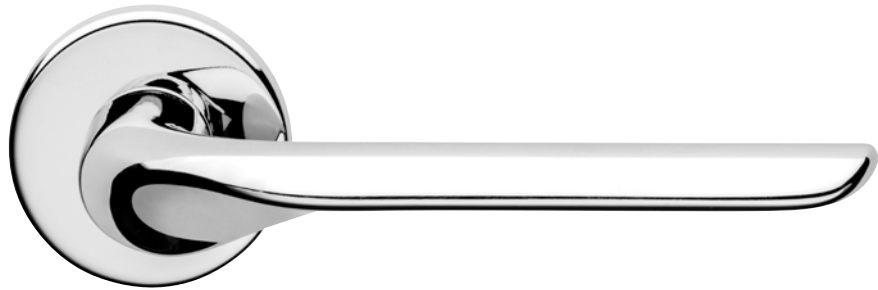

GP12
ZC

dnd 2018/2019

Zama
Zamak



ZC
Cromo lucido
Polished chrome



ZCS
Cromo satinato
Satin chrome



ZOL
Ottonato lucido
Polished brass color



ZGH
Bronzo satinato opaco
Matt satin bronze



ZNE
Nero
Black

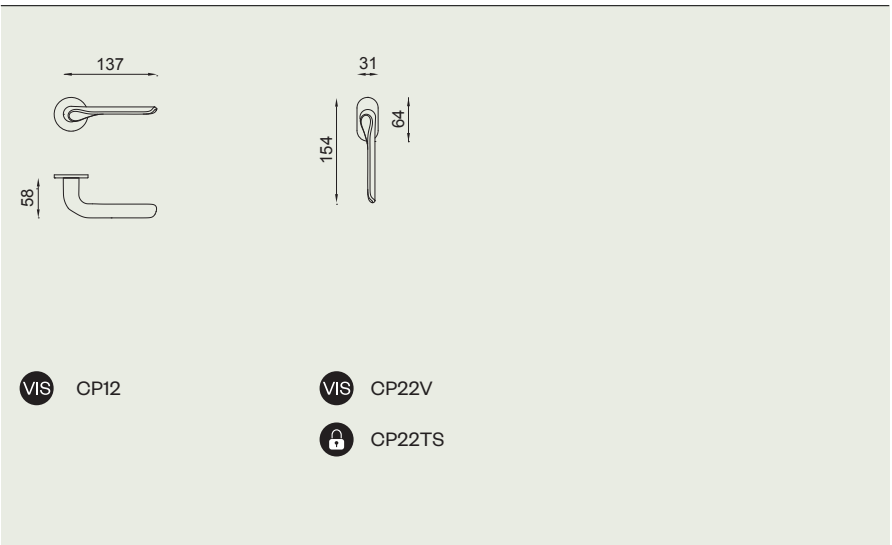

142-

143

fold

design:
Mario Padiglione

Zama
Zamak



ZC
Cromo lucido
Polished chrome



ZCS
Cromo satinato
Satin chrome



ZNE
Nero
Black



FO12
ZC

144-

dnd 2018/2019

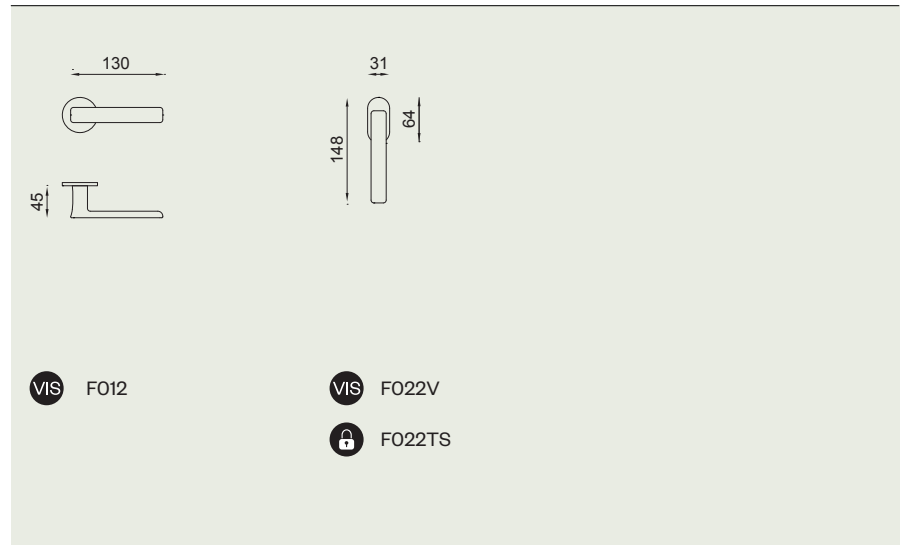

145

fold 02

design:
Mario Padiglione

Zama
Zamak



ZC
Cromo lucido
Chrome



ZCS
Cromo satinato
Satin chrome



ZNE
Nero
Black

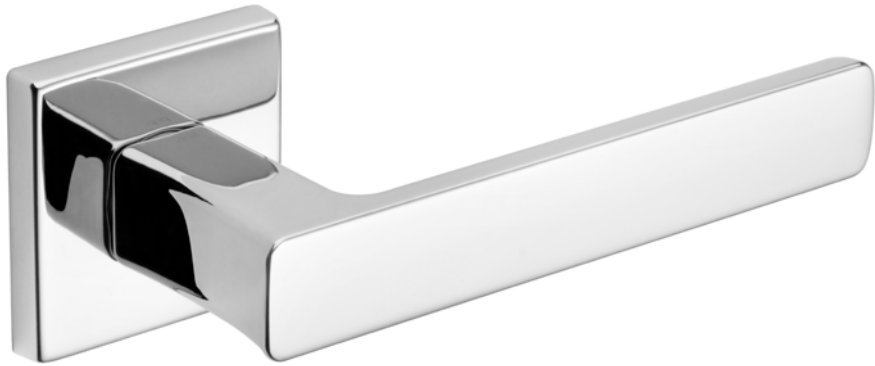

F014
ZC

146-

dnd 2018/2019

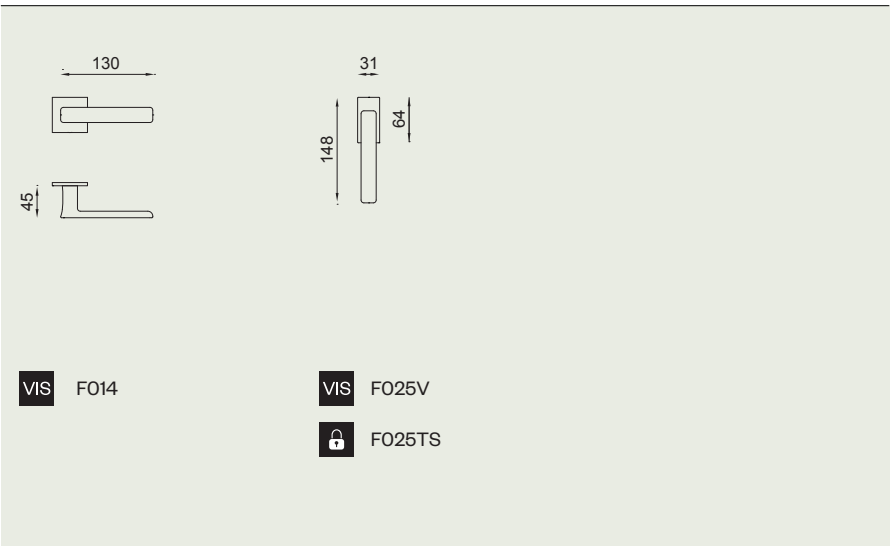

147

joy

design:
Nicola Novelletto



JO12
ZCS

Zama
Zamak



ZC
Cromo lucido
Polished chrome



ZCS
Cromo satinato
Satin chrome



ZNS
Nickel satinato
Satin nickel



ZNE
Nero
Black

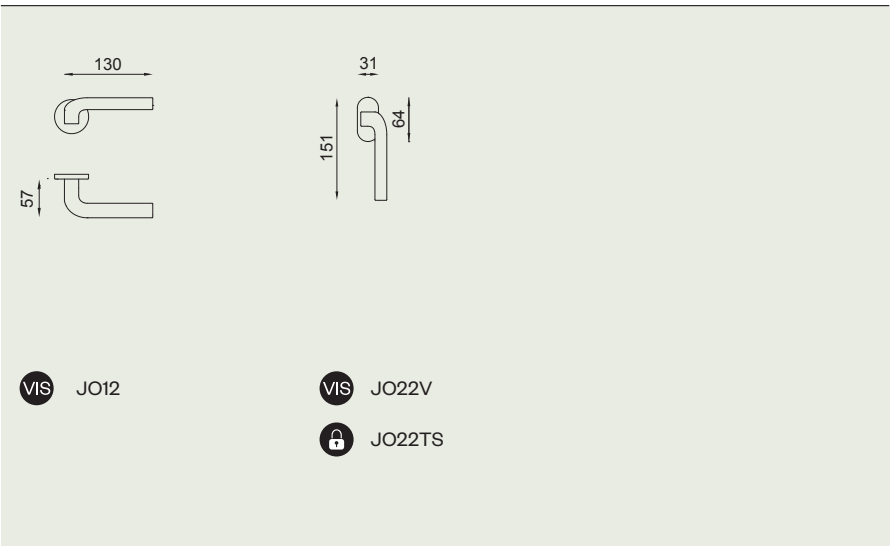

joy 02

design:
Nicola Novelletto



JO14
ZCS

150-

Zama
Zamak



ZC
Cromo lucido
Polished chrome



ZCS
Cromo satinato
Satin chrome



ZNS
Nickel satinato
Satin nickel



ZNE
Nero
Black

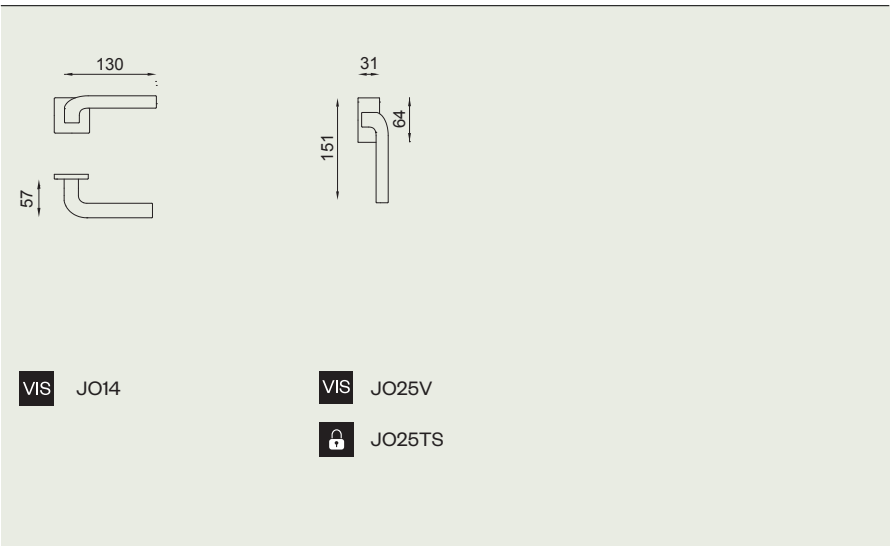

151

art

design:
Mauro Ronchi



AR40
OC

Ottone stampato a caldo
Hot stamped brass



OGH
Bronzo satinato opaco
Matt satin bronze



OC
Power cromo lucido
Power polished chrome



PCS
Power cromo satinato
Power satin chrome



ONS
Nickel satinato
Satin nickel



PVD*
PVD oro
Gold PVD

*** su ordinazione / on demand**

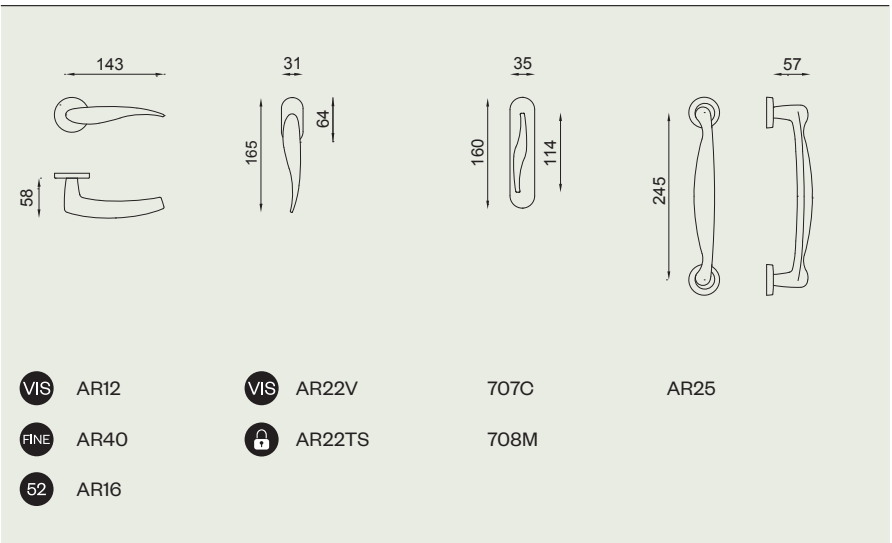

linear

design:
Mauro Ronchi

Ottone stampato a caldo
Hot stamped brass



AB
Bronzato
Antique bronze



OGH
Bronzo satinato opaco
Matt satin bronze



OC
Power cromo lucido
Power polished chrome



PCS
Power cromo satinato
Power satin chrome



LI40
AB

154-

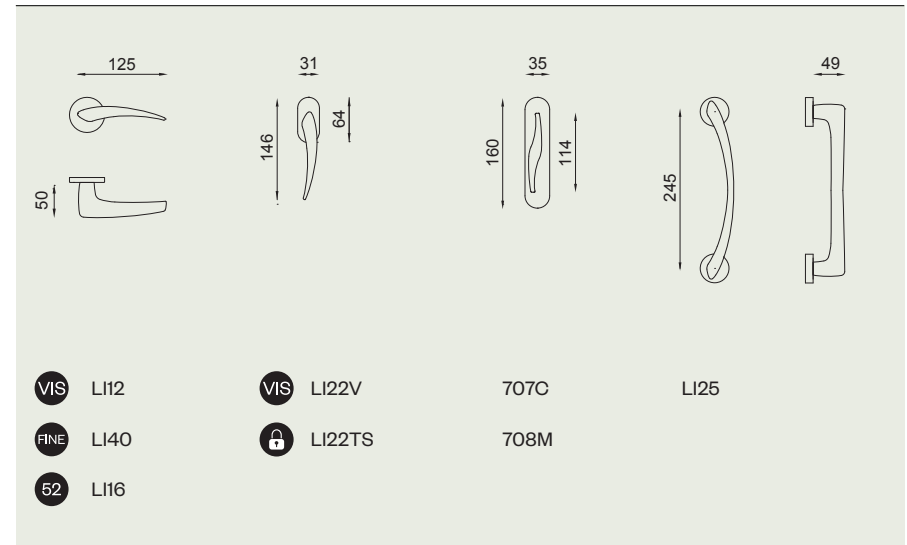

155

dolce

design:
Mauro Ronchi



DO40
OGH

Ottone stampato a caldo
Hot stamped brass



OGH
Bronzo satinato opaco
Matt satin bronze



OC
Power cromo lucido
Power polished chrome



PCS
Power cromo satinato
Power satin chrome



ONS
Nickel satinato
Satin nickel

*** su ordinazione / on demand**

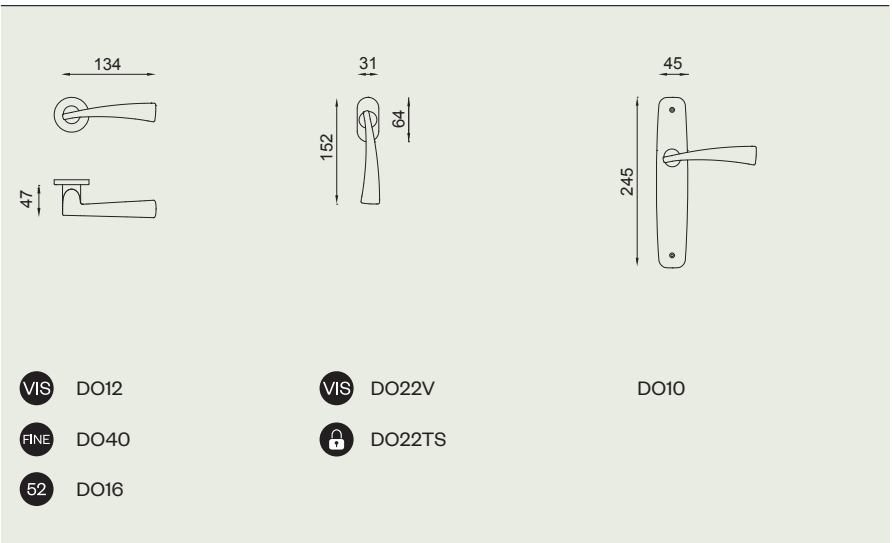

blip

design:
Karim Rashid

Ottone
Solid brass



OC
Power cromo lucido
Power polished chrome



PCS
Power cromo satinato
Power satin chrome



ONO
Nero
Black



BL16
OC

158-

dnd 2018/2019

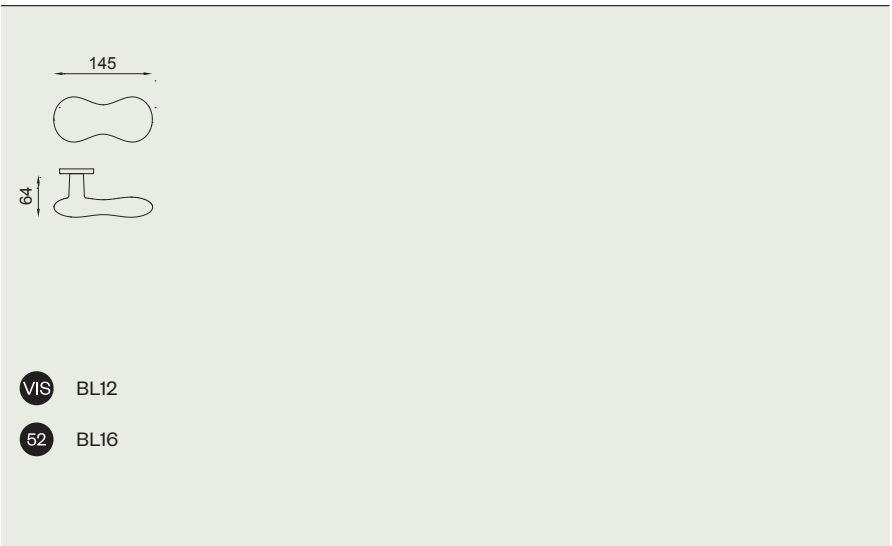

159

twist

design:
Karim Rashid

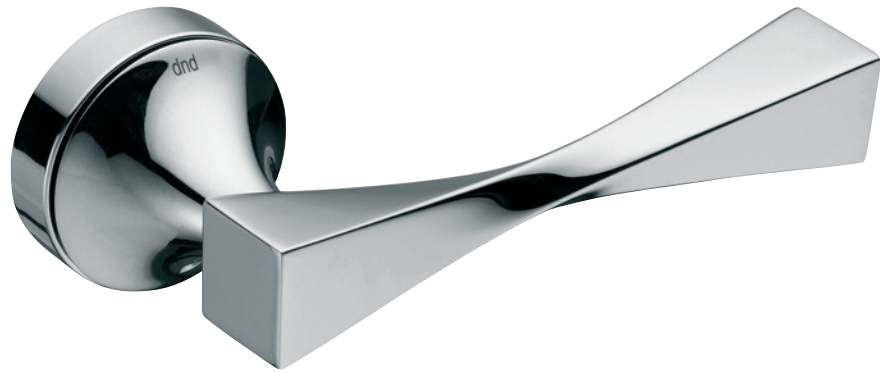

TW14
OC

160-

Ottone stampato a caldo
Hot stamped brass



OC
Power cromo lucido
Power polished chrome



PCS
Power cromo satinato
Power satin chrome



ONS*
Nickel satinato
Satin nickel

* **su ordinazione / on demand**

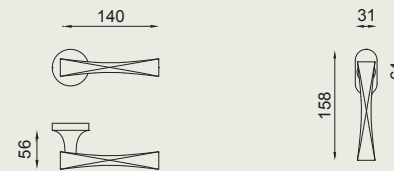

VIS TW12

FINE TW40

R TW14

VIS TW22V

🔒 TW22TS

twist 02

design:
Karim Rashid

Ottone stampato a caldo
Hot stamped brass



OC
Power cromo lucido
Power polished chrome



PCS
Power cromo satinato
Power satin chrome



ONS*
Nickel satinato
Satin nickel



*** su ordinazione / on demand**

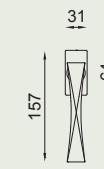
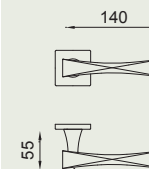

VIS TW13

TW25

FINE TW41

VIS TW25V

52 TW18

🔒 TW25TS

TW18
OC

162-

dnd 2018/2019

163

sike

design:
Karim Rashid

Ottone stampato a caldo
Hot stamped brass



OC
Power cromo lucido
Power polished chrome

PCS
Power cromo satinato
Power satin chrome



SK14
OC

164-

dnd 2018/2019

GOOD DESIGN

Good Design Awards 2006

SK12	SK22V
SK14	SK22TS

165

sike 02

design:
Karim Rashid

Ottone stampato a caldo
Hot stamped brass



OC
Power cromo lucido
Power polished chrome

PCS
Power cromo satinato
Power satin chrome



SK18
PCS

166-

dnd 2018/2019

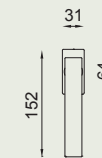
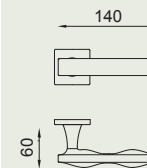

Good Design Awards
2006

VIS SK13

SK25

FINE SK41

VIS SK25V

52 SK18

SK25TS

167

nice

design:
Karim Rashid

Ottone stampato a caldo
Hot stamped brass



OC
Power cromo lucido
Power polished chrome

PCS
Power cromo satinato
Power satin chrome



NI40
PCS

168-

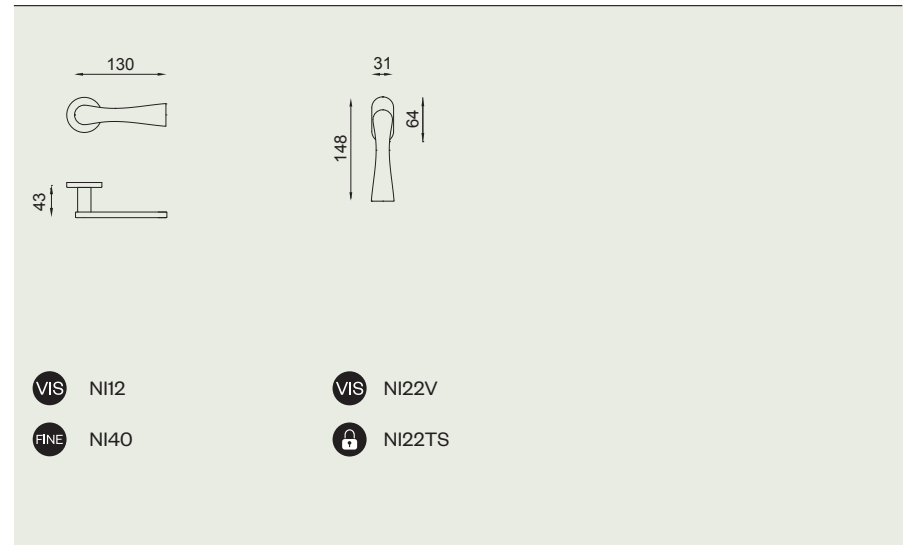

169

short

design:
Karim Rashid

Ottone stampato a caldo
Hot stamped brass



AB
Bronzato
Antique bronze



OC
Power cromo lucido
Power polished chrome



PCS
Power cromo satinato
Power satin chrome



SH40
OC

170-

dnd 2018/2019

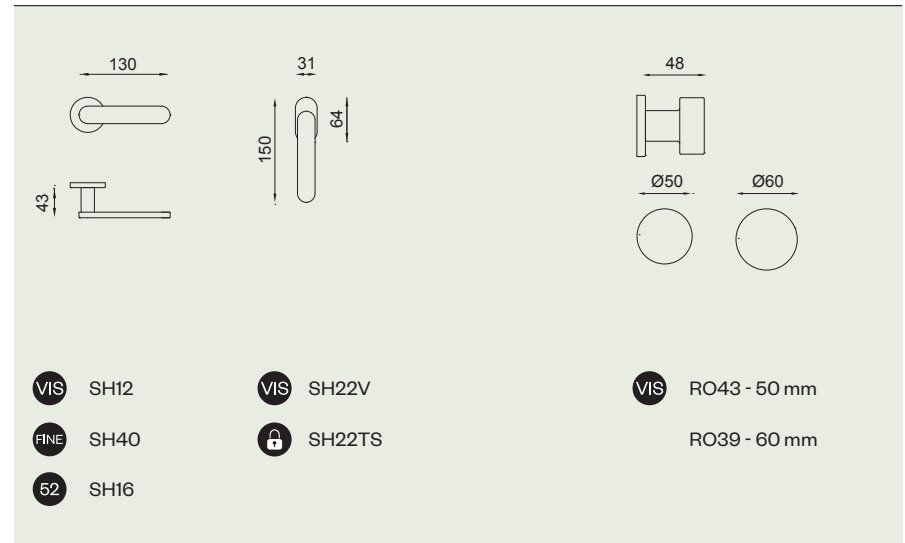

171

project

design: **Dnd**
technical division



PR12
PCS

Ottone stampato a caldo
Hot stamped brass



AB
Bronzato
Antique bronze



OC
Power cromo lucido
Power polished chrome



PCS
Power cromo satinato
Power satin chrome



ONS
Nickel satinato
Satin nickel



ONO
Nero
Black



V702
Marrone
Brown

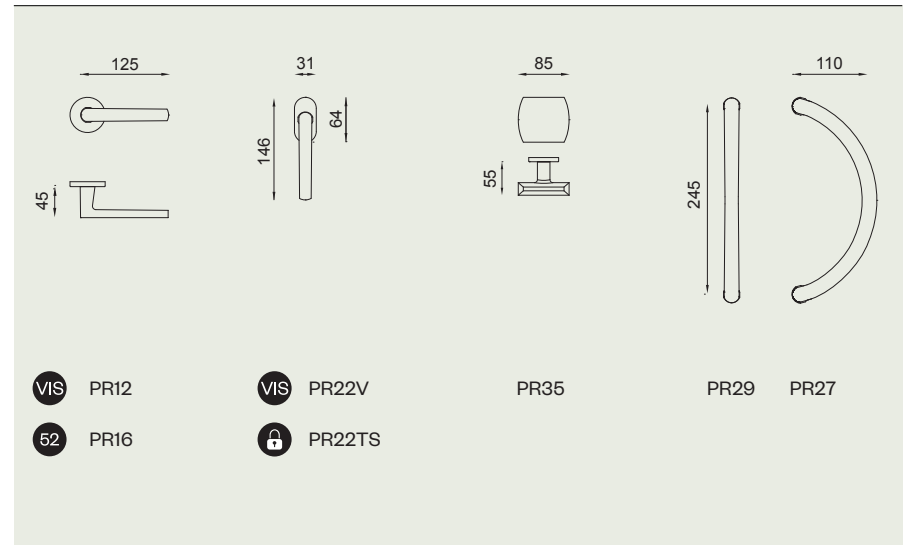

VIS PR12

62 PR16

VIS PR22V

PR22TS

PR35

PR29 PR27

project 02

design: Dnd
technical division

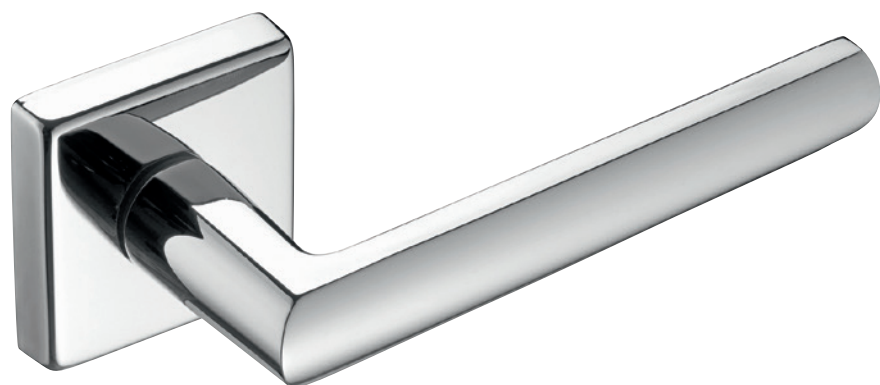

PR14
OC

Ottone stampato a caldo
Hot stamped brass



AB
Bronzato
Antique bronze



OC
Power cromo lucido
Power polished chrome



PCS
Power cromo satinato
Power satin chrome



ONS
Nickel satinato
Satin nickel



ONO
Nero
Black



V702
Marrone
Brown

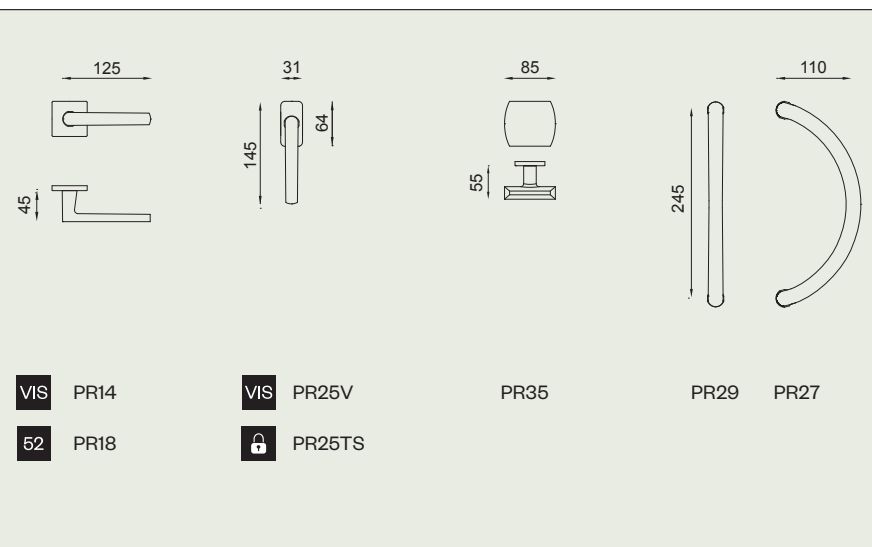

project zancata

design: Dnd
technical division



PO12
OC

Ottone
Solid brass



OC
Power cromo lucido
Power polished chrome



PCS
Power cromo satinato
Power satin chrome



PVD *
PVD oro
Gold PVD



project z. 02 - OC
Power cromo lucido
Power polished chrome



project z. 02 - PCS
Power cromo satinato
Power satin chrome



project z. 02 - ONS *
Nickel satinato
Satin nickel

* su ordinazione / on demand

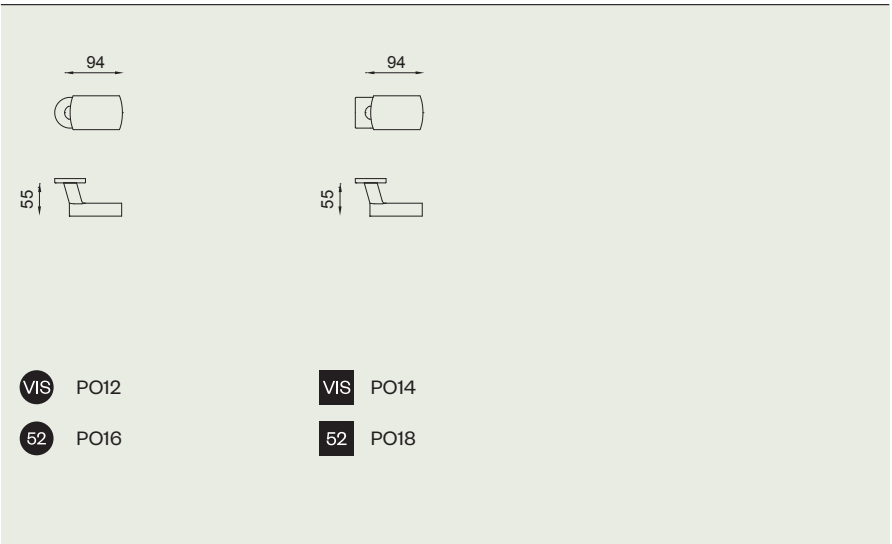

logo

design:
Mauro Ronchi

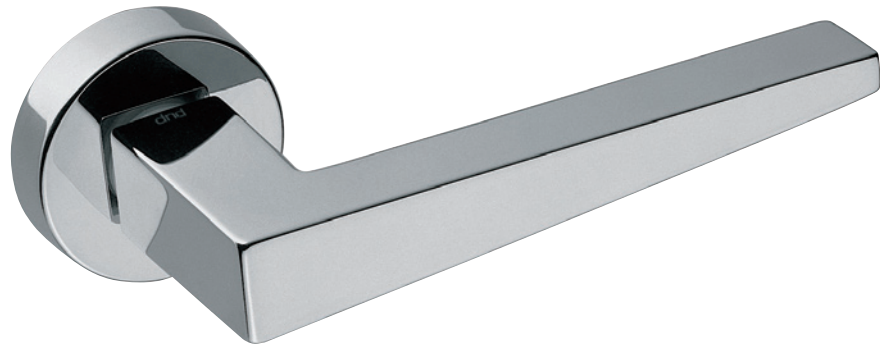

LO12
OC

178-

Ottone stampato a caldo
Hot stamped brass



OC
Power cromo lucido
Power polished chrome



PCS
Power cromo satinato
Power satin chrome



ONS
Nickel satinato
Satin nickel



logo B - CCS
Cromo - Power cromo satinato
Chrome - Power satin chrome

Fino esaurimento scorte
While still in stock

	LO12		LO22V		LB12		LB22V
	LO40		LO22TS		LB16		LB22TS
	LO16						

179

dnd 2018/2019

logo 02

design:
Mauro Ronchi



LO14
OC

180-

Ottone stampato a caldo
Hot stamped brass



OC
Power cromo lucido
Power polished chrome



PCS
Power cromo satinato
Power satin chrome



ONS
Nickel satinato
Satin nickel



logo B 02 - CCS
Cromo - Power cromo satinato
Chrome - Power satin chrome

Fino esaurimento scorte
While still in stock

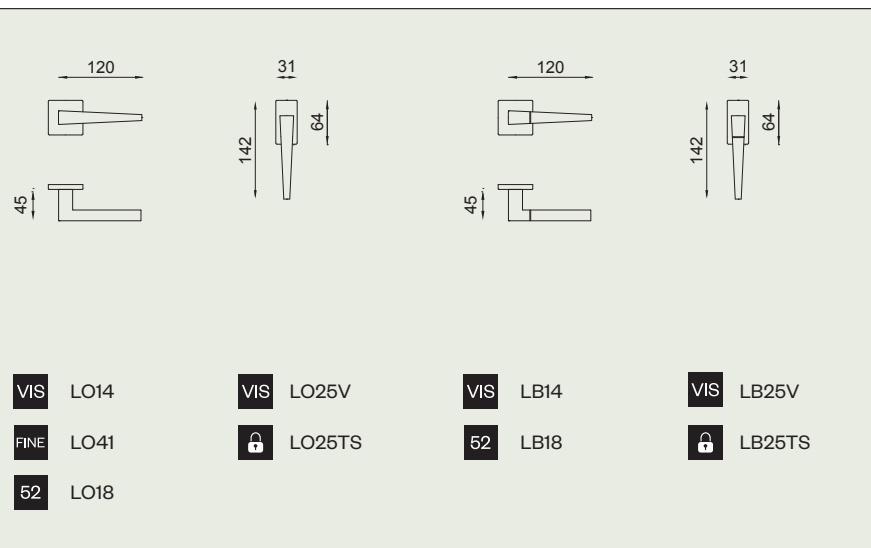

181

havana

design:
Studio Hot Lab



HV12
OLV+PA

Ottone stampato a caldo
Hot stamped brass



OLV+PA
Ottone lucido + Papaya
Polished brass + Papaya



OC+NA
Power cromo lucido + Navy
Power polished chrome + Navy



PCS+PA
Power cromo satinato + Papaya
Power satin chrome + Papaya



PCS+NA
Power cromo satinato + Navy
Power satin chrome + Navy

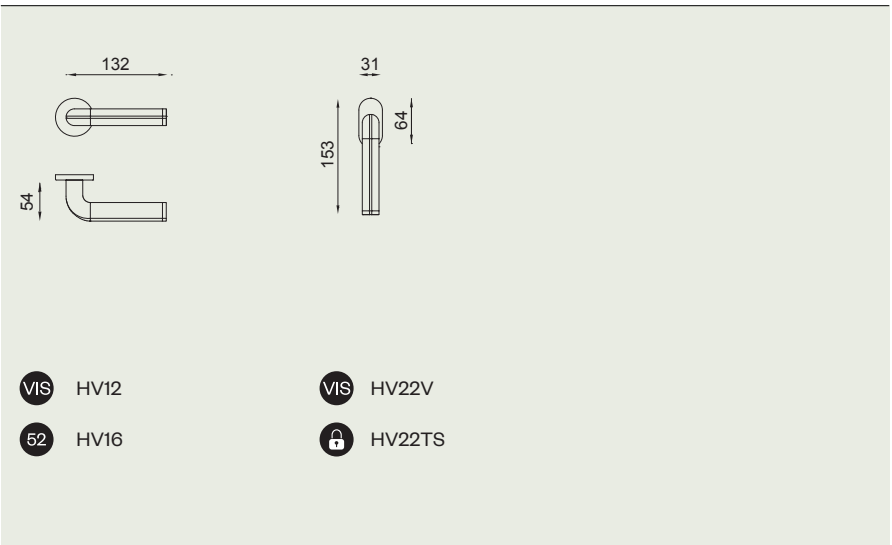

movida

design:
Mauro Ronchi



MV16
OC

184-

Ottone stampato a caldo
Hot stamped brass



OC
Power cromo lucido
Power polished chrome



PCS
Power cromo satinato
Power satin chrome



PGS*
PVD grafite satinato
Satin graphite PVD

*** su ordinazione / on demand**

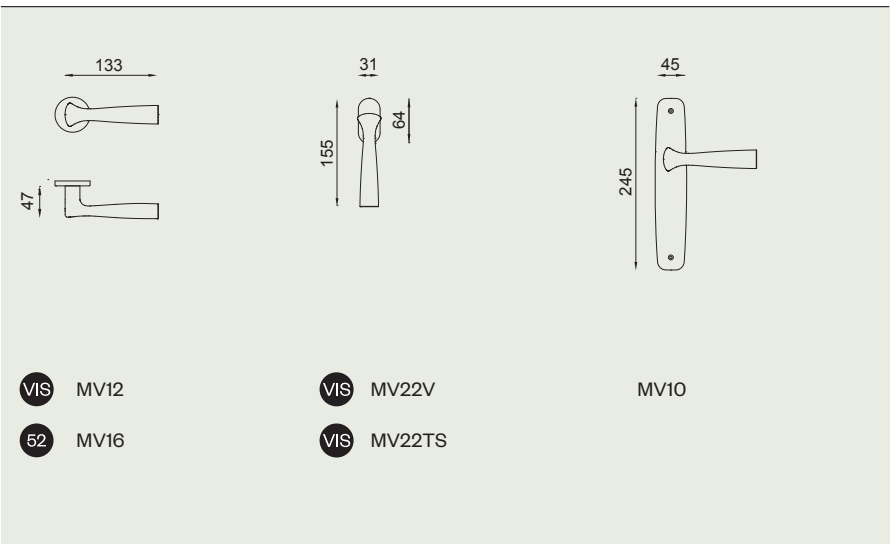

185

dnd 2018/2019

sochic

design: Dnd
technical division



SC12
ZC

Zama
Zamak



ZC
Cromo lucido
Polished chrome



ZOR
Placcato oro 24 k
Gold plated 24 k



sochic 02 - ZC
Cromo lucido
Polished chrome



sochic 02 - ZOR
Placcato oro 24 k
Gold plated 24 k

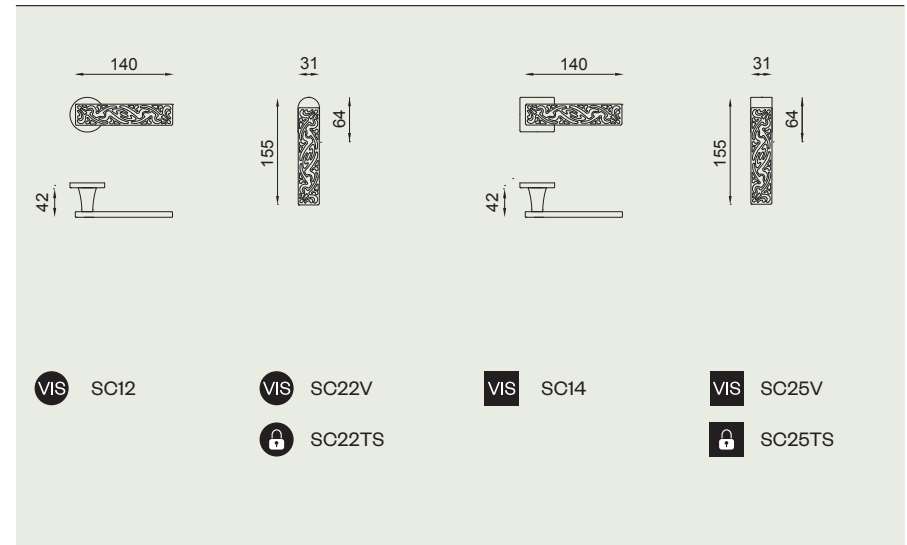

187

186-

sochic L

design: Dnd
technical division



SL41
CPL

Zama
Zamak



CLS
Cromo lucido
+ inserto larice sabbia
Polished chrome
+ sand-tone larch insert



CPB
Cromo lucido
+ inserto palissandro bianco
Polished chrome
+ white rosewood insert



sochic L 02 - SPL
Cromo satinato
+ inserto palissandro scuro
Satin chrome
+ dark rosewood insert



sochic L 02 - SRT
Cromo satinato
+ inserto rovere tanchè
Satin chrome
+ tanché Oakwood insert

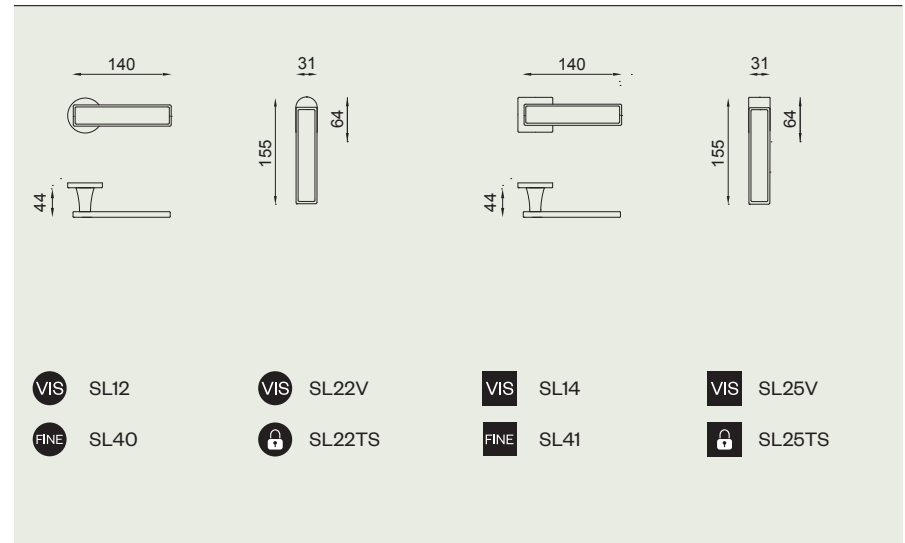

189

188-

vita

design:
Mauro Ronchi



VI12
PVD

190-

Ottone stampato a caldo
Hot stamped brass



OC
Power cromo lucido
Power polished chrome



PCS
Power cromo satinato
Power satin chrome



ONS*
Nickel satinato
Satin nickel



PGS*
PVD grafite satinato
Satin graphite PVD



PVD*
PVD oro
Gold PVD



PVX*
PVD inox
Steel PVD

* **su ordinazione** / *on demand*

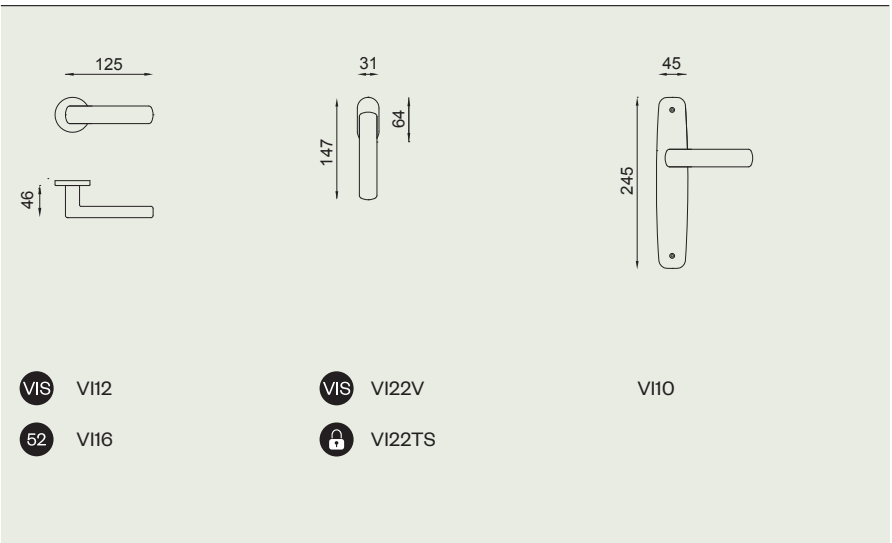

191

dnd 2018/2019

vita 02

design:
Mauro Ronchi



VI18
OC

Ottone stampato a caldo
Hot stamped brass



OC
Power cromo lucido
Power polished chrome



PCS
Power cromo satinato
Power satin chrome



PGS*
PVD grafite satinato
Satin graphite PVD



ONS*
Nickel satinato
Satin nickel



PVX*
PVD inox
Steel PVD

Fino esaurimento scorte (rosetta 52)
While still in stock (52 rose)

*** su ordinazione / on demand**

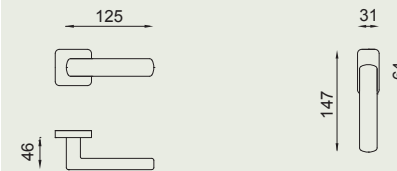

VIS VI14

52 VI18

VIS VI25V

🔒 VI25TS

vita B

design:
Mauro Ronchi



VB12
PGS

Ottone stampato a caldo
Hot stamped brass



CCS
Cromo - Power cromo satinato
Chrome - Power satin chrome



PGS*
PVD grafite satinato
Satin graphite PVD



ONS*
Nickel satinato
Satin nickel



vita B 02 - CCS
Cromo - Power cromo satinato
Chrome - Power satin chrome



vita B 02 - PGS*
PVD grafite satinato
Satin graphite PVD



vita B 02 - ONS*
Nickel satinato
Satin nickel

Fino esaurimento scorte (rosetta 52)
While still in stock (52 rose)

* su ordinazione / on demand

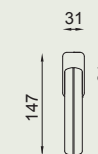
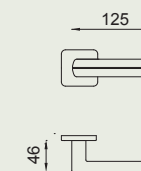
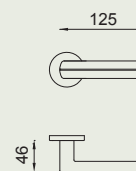

VIS VB12

VIS VB22V

VIS VB14

VIS VB25V

52 VB16

52 VB22TS

52 VB18

52 VB25TS

vita legno

design:
Mauro Ronchi



VL16
TNO

dnd 2018/2019

Ottone stampato a caldo
Hot stamped brass



TNO
Power cromo satinato
+ Legno noce
Power satin chrome + walnut



NNO
Nickel satinato
+ Legno noce
Satin nickel + walnut



vita legno 02 - TNO *
Power cromo satinato
+ Legno noce
Power satin chrome + walnut



vita legno 02 - NNO *
Nickel satinato
+ Legno noce
Satin nickel + walnut

Fino esaurimento scorte (rosetta 52)
While still in stock (52 rose)

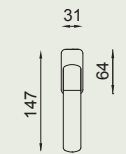
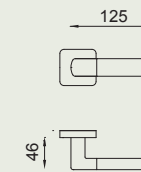
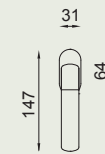
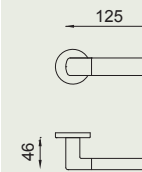

VIS VL12

VIS VL22V

VIS VL14

VIS VL25V

52 VL16

52 VL22TS

52 VL18

52 VL25TS

ego

design:
Mauro Ronchi



EG16
OC

Ottone
Solid brass



OC
Power cromo lucido
Power polished chrome



PCS
Power cromo satinato
Power satin chrome



PVX *
PVD inox
Steel PVD



PVD *
PVD oro
Gold PVD

* **su ordinazione** / on demand



VIS EG12

52 EG16

fluò

design:
Mauro Ronchi

Ottone stampato a caldo
Hot stamped brass



OLV
Lucido
Polished



OC
Power cromo lucido
Power polished chrome



PCS
Power cromo satinato
Power satin chrome



FL16
OLV

200-

dnd 2018/2019

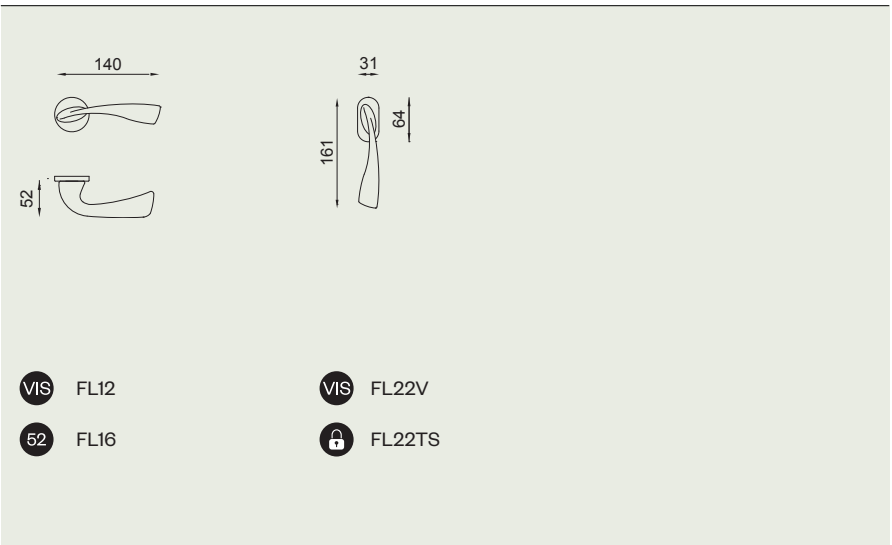

201

design:
Mauro Ronchi

Ottone stampato a caldo
Hot stamped brass



OC
Power cromo lucido
Power polished chrome



PCS
Power cromo satinato
Power satin chrome



GO16
OC

202-

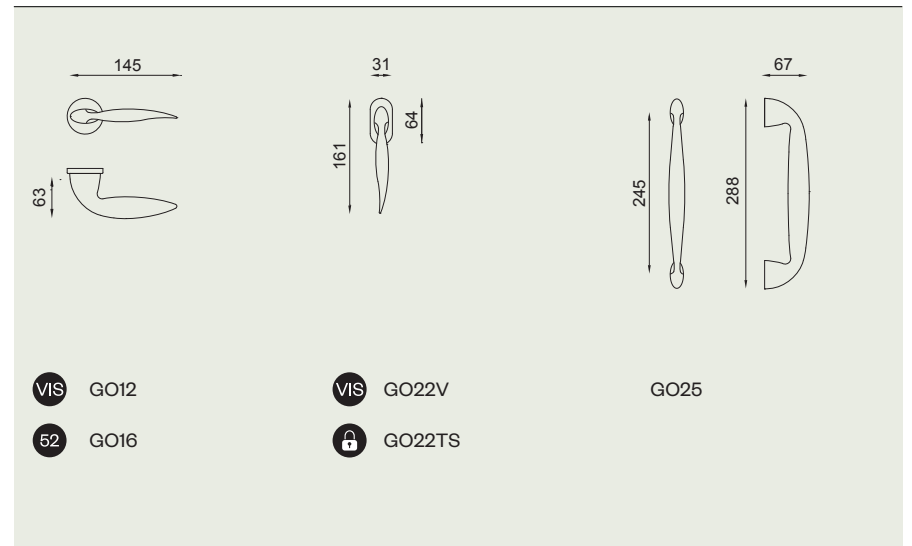

203

mix

design: Dnd
technical division



MI12
OC+R

204-

Ottone, zama e acciaio
Brass, zamak and stainless steel



OC + R
Cromo lucido + rete
Polished chrome + screen



OCS + R
Cromo satinato + rete
Satin chrome + screen



CNE
Cromo lucido - nero
Polished chrome - black



CSNE
Cromo satinato - nero
Satin chrome - black

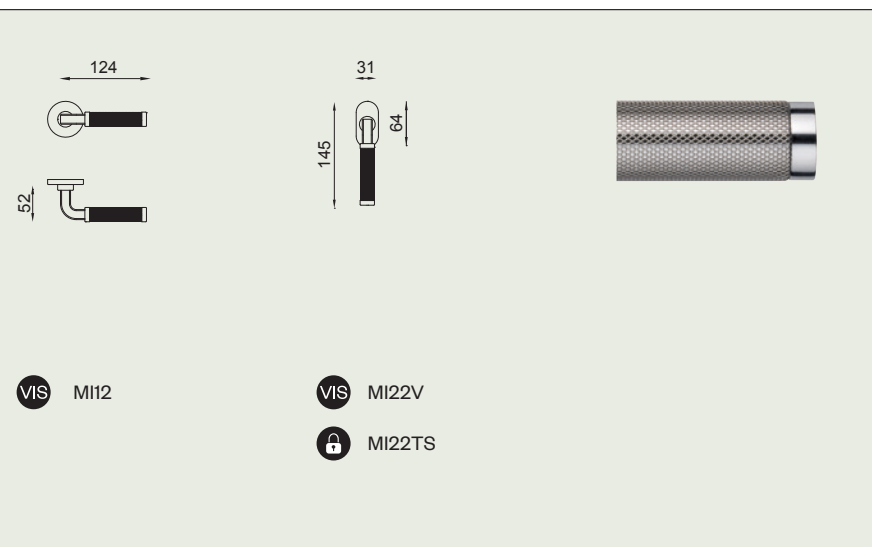

205

dnd 2018/2019

grip

design:
Novelletto - Greco

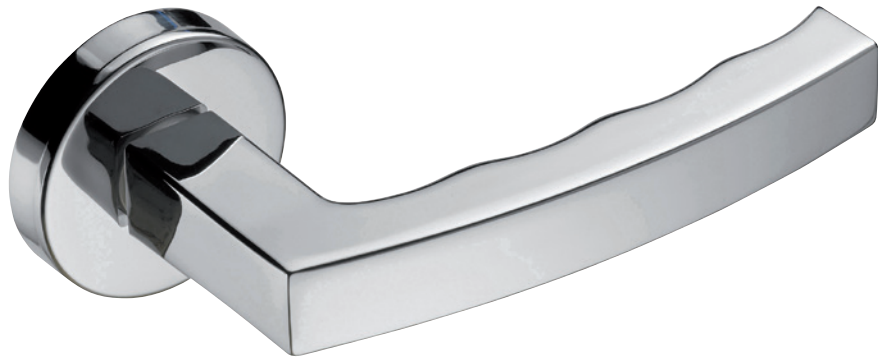

852/12
ZC

206-

dnd 2018/2019

Zama
Zamak



ZC
Cromo lucido
Polished chrome



ZCS
Cromo satinato
Satin chrome



grip 02 - ZC
Cromo lucido
Polished chrome



grip 02 - ZCS
Cromo satinato
Satin chrome

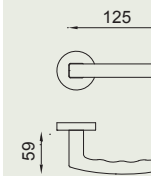

VIS 852/12

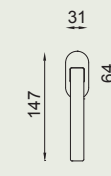

VIS 857V

857TS

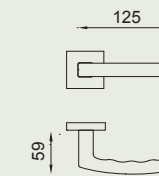

VIS 851/14

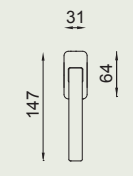

VIS 856V

856TS

207

stick 02

design:
Novelletto - Greco

Zama
Zamak



ZC
Cromo lucido
Polished chrome



ZCS
Cromo satinato
Satin chrome



861/14
ZC

208-

dnd 2018/2019

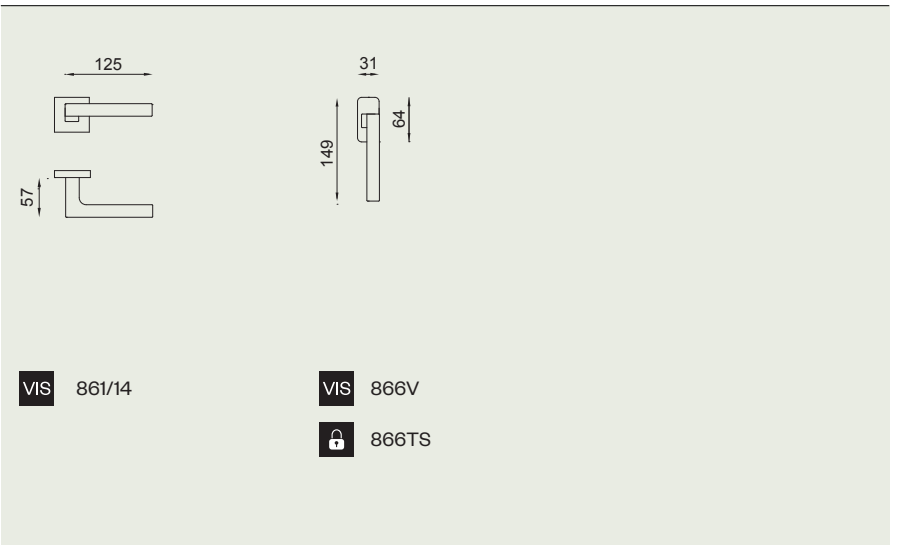

209

maniglie

classic

– classic
handles

fiorenza

design: Dnd
technical division



520
ORO

Ottone stampato a caldo
Hot stamped brass



OGH
Bronzo satinato opaco
Matt satin bronze



ONV
Nickel lucido
Polished nickel



OROF
Oro francese
French gold



ORO*
Placcato oro 24k
Gold plated 24k

* **su ordinazione** / *on demand*

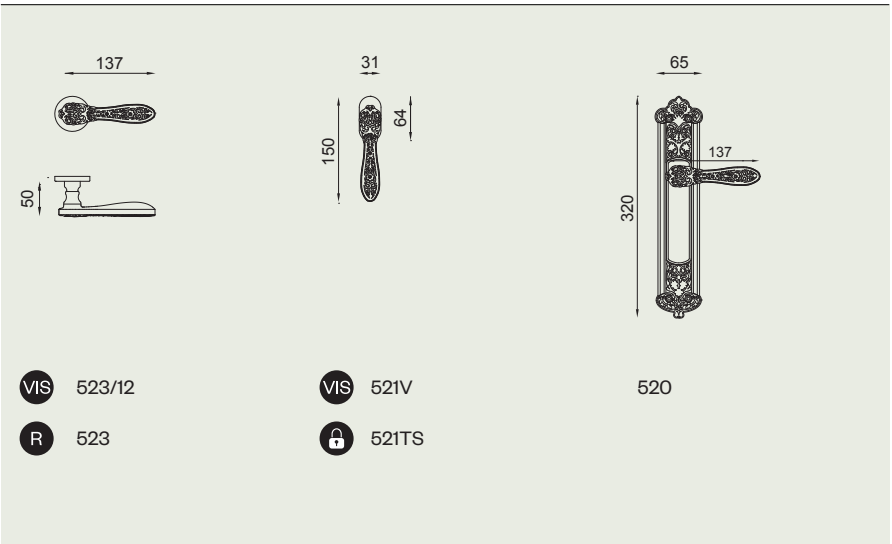

design: Dnd
technical division



525
OGH

Ottone stampato a caldo
Hot stamped brass



OGH
Bronzo satinato opaco
Matt satin bronze



ONV
Nickel lucido
Polished nickel



OROF
Oro francese
French gold



ORO*
Placcato oro 24k
Gold plated 24k

* **su ordinazione** / *on demand*

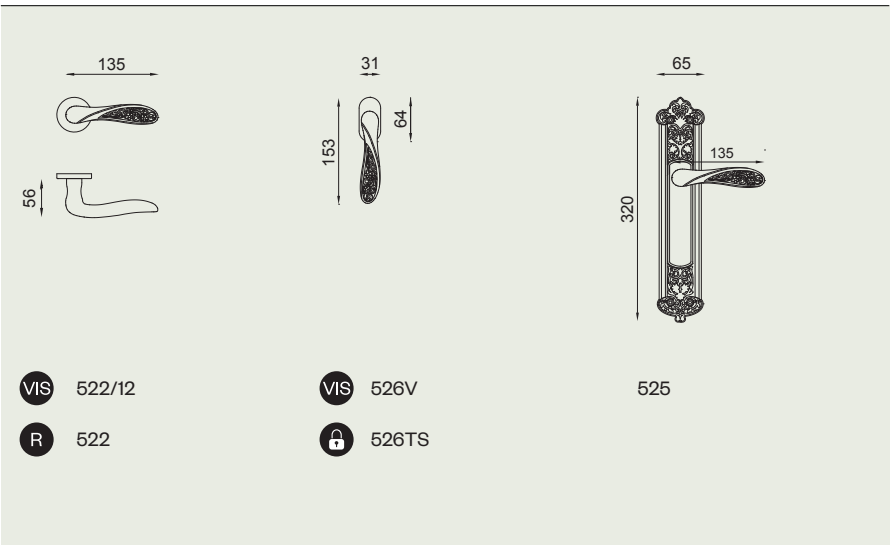

fedora

design: Dnd
technical division

Ottone stampato a caldo
Hot stamped brass



AB
Bronzato
Antique bronze



OGH
Bronzo satinato opaco
Matt satin bronze



PCS
Power cromo satinato
Power satin chrome



530/12
AB

216-

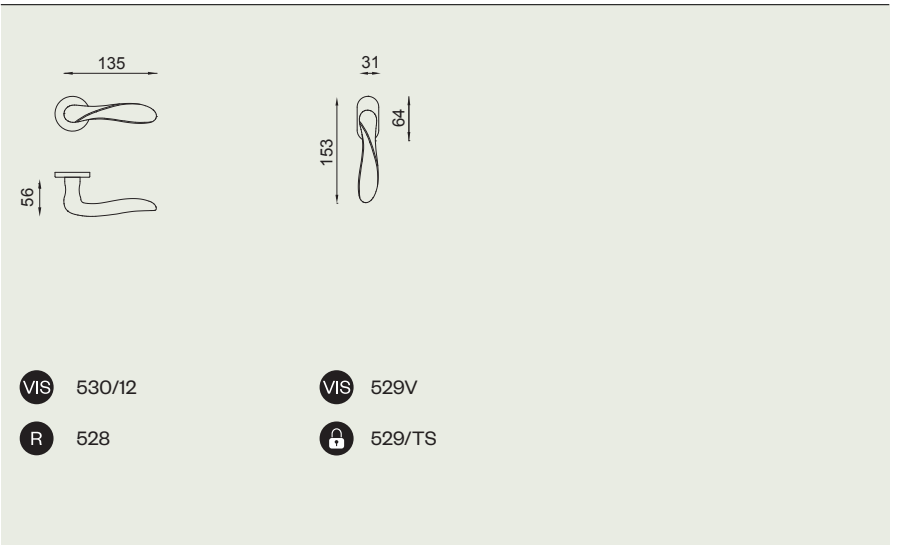

217

lirica

design: Dnd
technical division



806/12
ONV

Ottone
Solid brass



OLV
Lucido
Polished



AF
Anticato
Antique finish



BSS
Bronzo scuro sfumato
Shaded dark bronze



FAN
Ferro anticato
Antique iron



ONV
Nickel lucido
Polished nickel

* su ordinazione / on demand

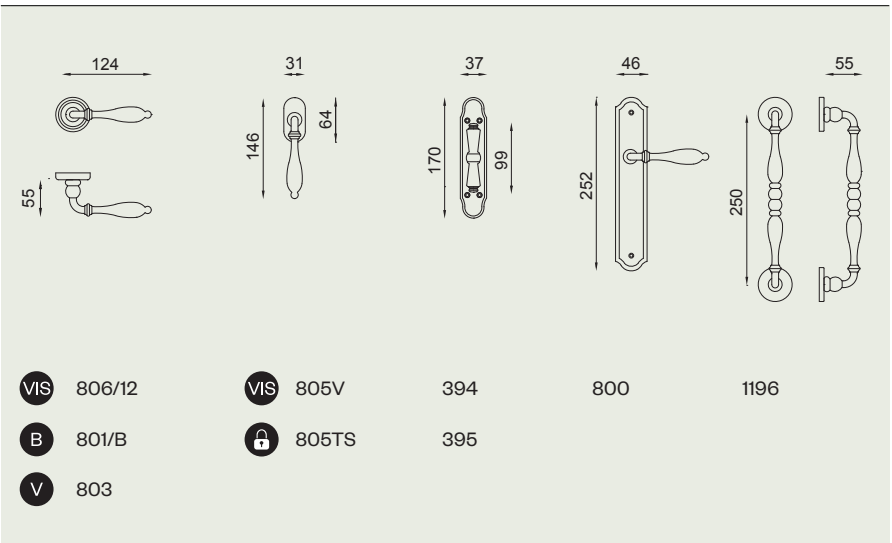

classic

design: Dnd
technical division

Ottone
Solid brass



OLV
Lucido
Polished



AB
Bronzato
Antique bronze



OGH
Bronzo satinato opaco
Matt satin bronze



571/12
OLV

220-

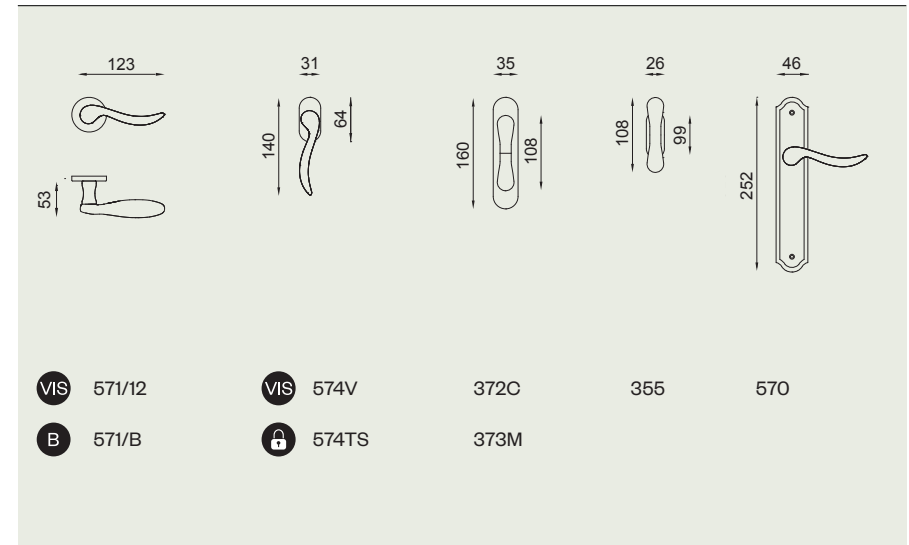

221

classic due

design: Dnd
technical division

Ottone
Solid brass



OLV
Lucido
Polished



AB
Bronzato
Antique bronze



OGH
Bronzo satinato opaco
Matt satin bronze



576/12
OGH

222-

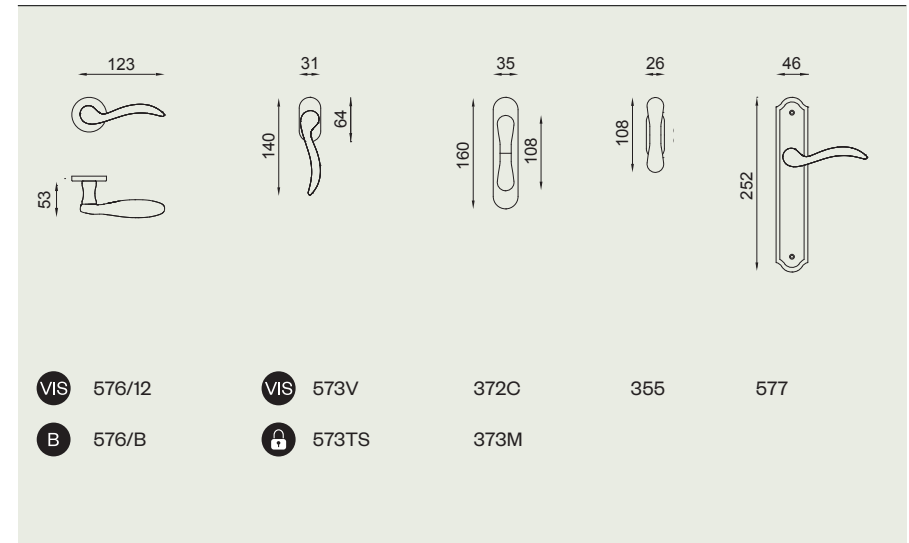

223

ardea

design:
Mauro Ronchi

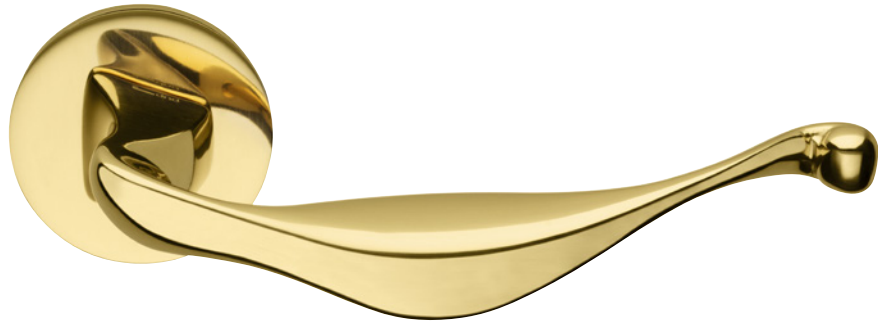

AD12
OLV

Ottone stampato a caldo
Hot stamped brass



OLV
Lucido
Polished



OGH
Bronzo satinato opaco
Matt satin bronze



ONV
Nickel lucido
Polished nickel



OLV
Lucido
Polished



ONV
Nickel lucido
Polished nickel

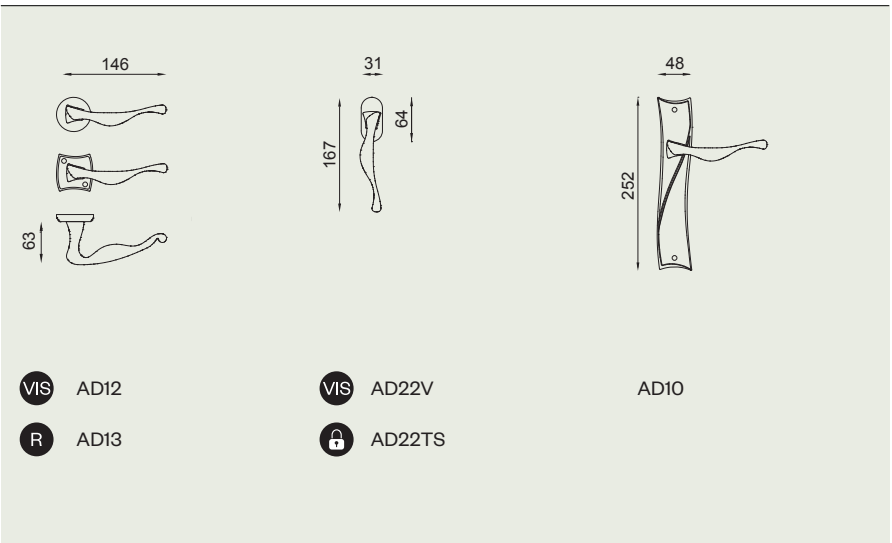

cassia

design:
Mauro Ronchi

Ottone stampato a caldo
Hot stamped brass



OLV
Lucido
Polished



OGH
Bronzo satinato opaco
Matt satin bronze



CA13
OLV

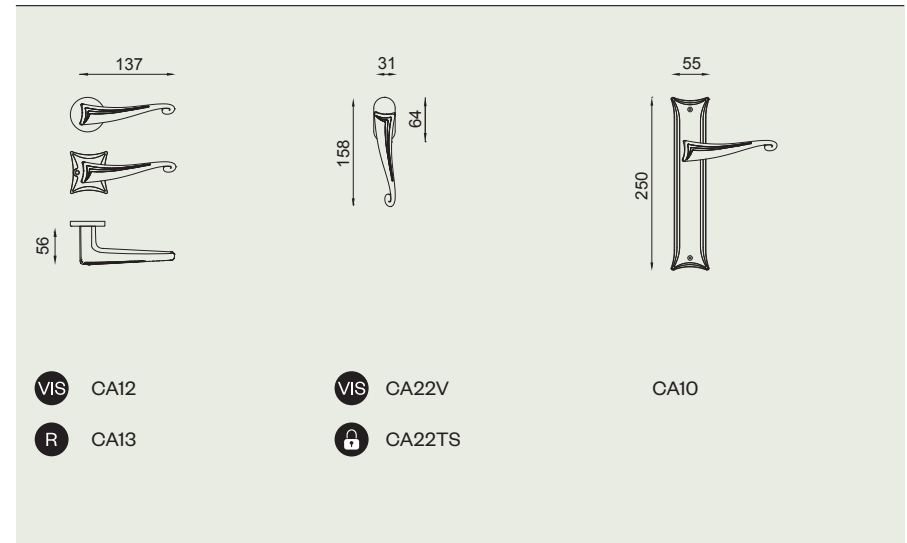

beverly

design:
Mauro Ronchi

Ottone stampato a caldo
Hot stamped brass



OLV
Lucido
Polished



OGH
Bronzo satinato opaco
Matt satin bronze



141/12
OLV

228-

dnd 2018/2019

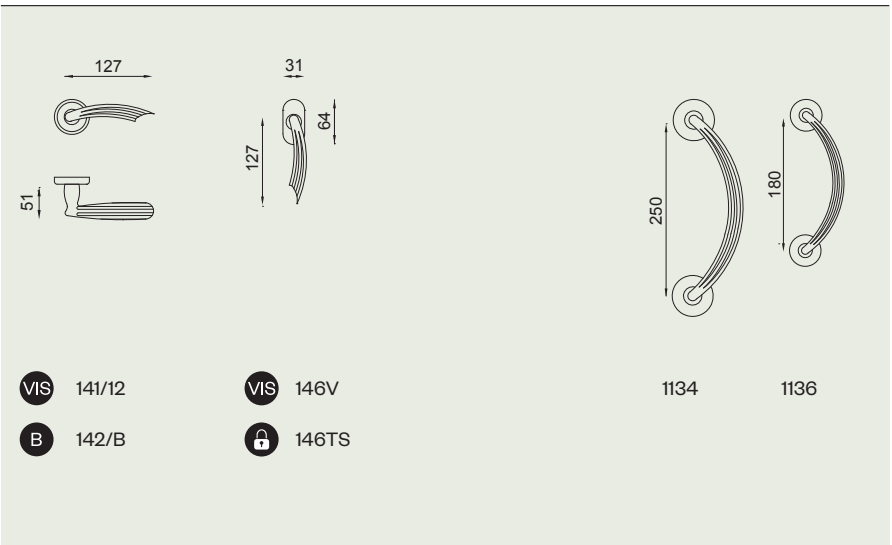

229

lady

design: Dnd
technical division

Ottone stampato a caldo
Hot stamped brass



OLV
Lucido
Polished



OGC
Bronzo satinato lucido
Bright satin bronze



OGH
Bronzo satinato opaco
Matt satin bronze



BSS
Bronzo scuro sfumato
Shaded dark bronze



568/B
OLV

230-

dnd 2018/2019

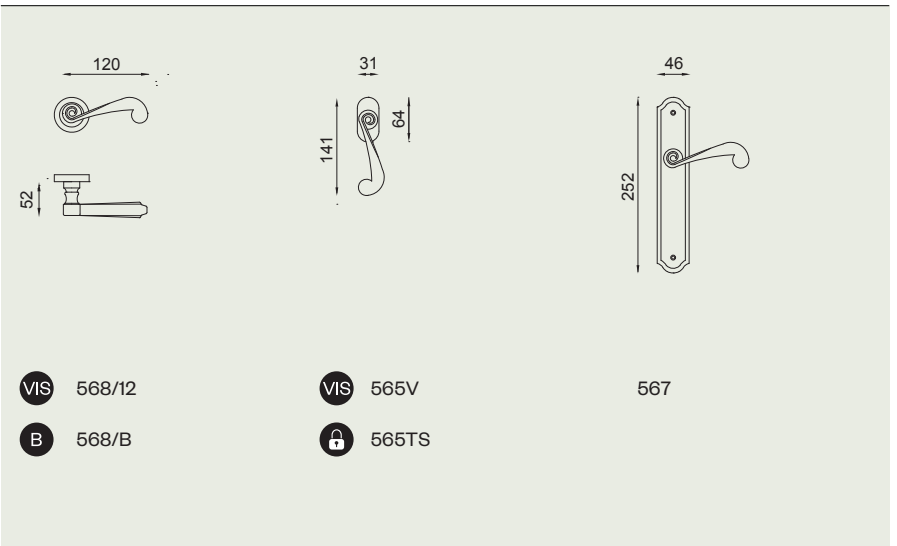

231

latina

design:
Mauro Ronchi

Ottone stampato a caldo
Hot stamped brass



OLV
Lucido
Polished



OGH
Bronzo satinato opaco
Matt satin bronze



BSS
Bronzo scuro sfumato
Shaded dark bronze



823/12
OLV

232-

dnd 2018/2019

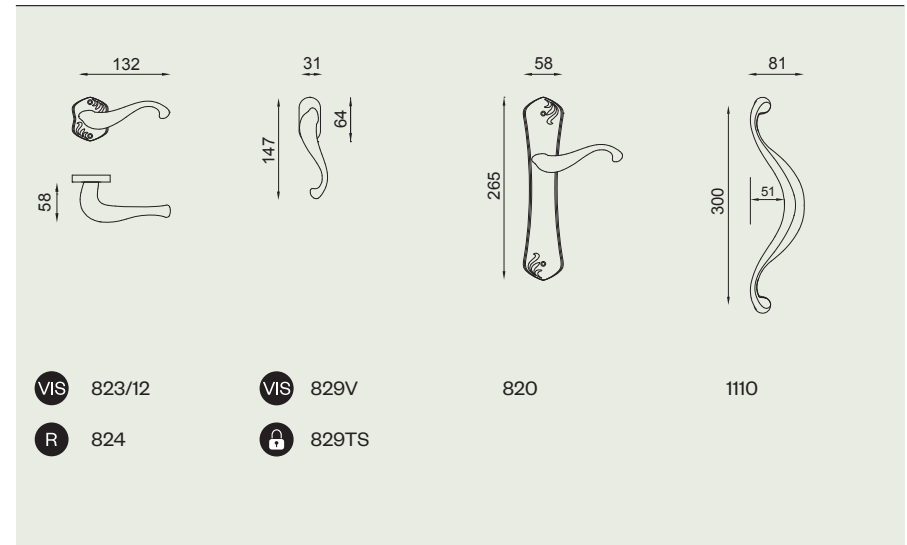

233

appia

design:
Mauro Ronchi

Ottone stampato a caldo
Hot stamped brass



OLV
Lucido
Polished



OGH
Bronzo satinato opaco
Matt satin bronze



BSS
Bronzo scuro sfumato
Shaded dark bronze



833/12
BSS

234-

dnd 2018/2019

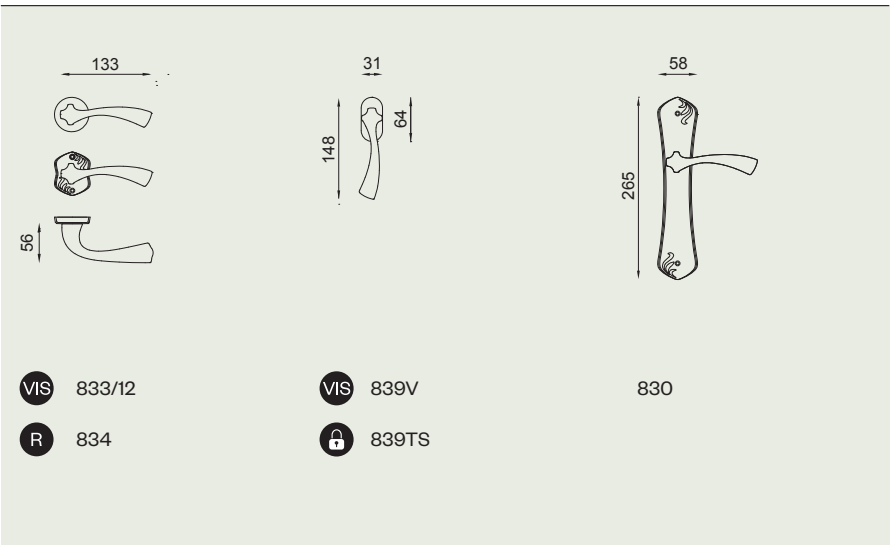

235

monica

design: Dnd
technical division

Ottone
Solid brass



OLV+P1
Lucido
Polished



AF+P8
Anticato
Antique finish



ONV+P1
Nickel lucido
Polished nickel



P1 = Porcellana bianca - White porcelain

P8 = Porcellana beige "Crackled" - Beige "Crackled" porcelain

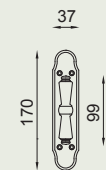
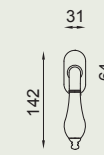
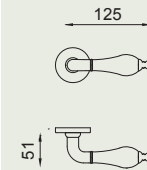

VIS 467/12

VIS 462V

394

LOCK 462TS

395

467/12
ONV+P1

236-

dnd 2018/2019

237

sinfonia

design: Dnd
technical division

Ottone
Solid brass



AB+P4
Bronzato
Antique bronze

OGH+P4
Bronzo satinato opaco
Matt satin bronze



P4 = Porcellana beige con decalcomania - beige porcelain with transfer

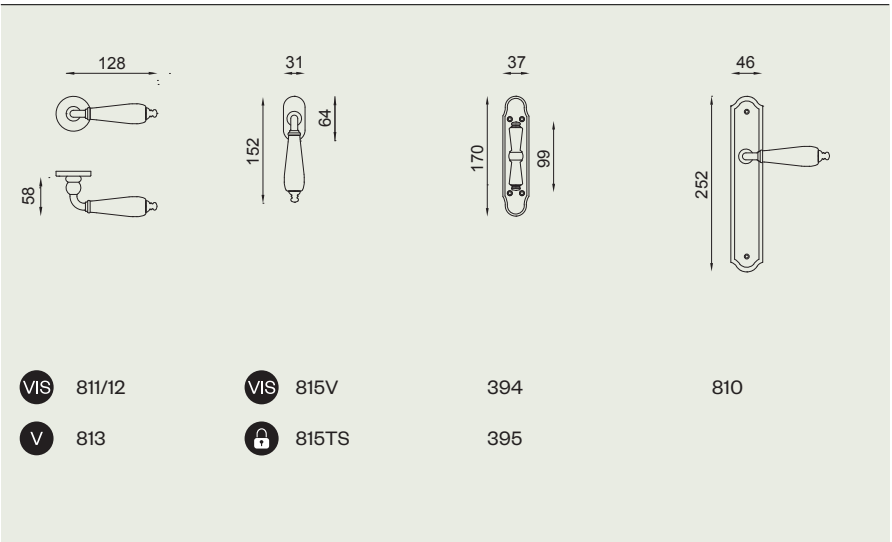

811/12
OGH+P4

238-

dnd 2018/2019

239

airone

design:
Mauro Ronchi



603/12
OLV

240-

Ottone
Solid brass



OLV
Lucido
Polished



OGC
Bronzo satinato lucido
Bright satin bronze



OC
Cromo lucido
Polished chrome



OCS
Cromo satinato
Satin chrome



OS*
Satinato
Satin

* su ordinazione / on demand

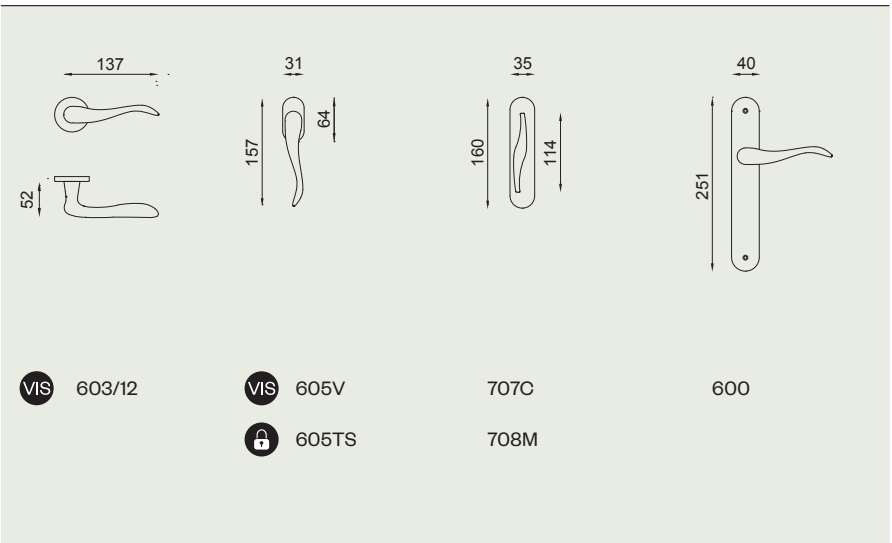

VIS 603/12

VIS 605V

707C

600

LOCK 605TS

708M

lorena

design: Dnd
technical division

Ottone
Solid brass



OLV
Lucido
Polished

AB
Bronzato
Antique bronze



251/12
OLV

242-

dnd 2018/2019

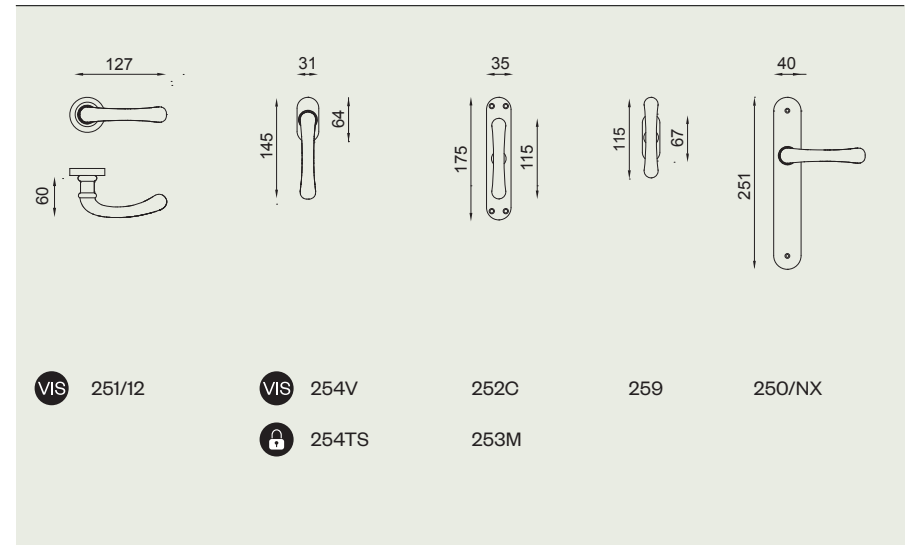

243

daniela

design: Dnd
technical division

Ottone
Solid brass



OLV
Lucido
Polished



AB
Bronzato
Antique bronze



AF
Anticato
Antique finish



FAN
Ferro anticato
Antique iron



ONV
Nickel lucido
Polished nickel



391/12
OLV

244-

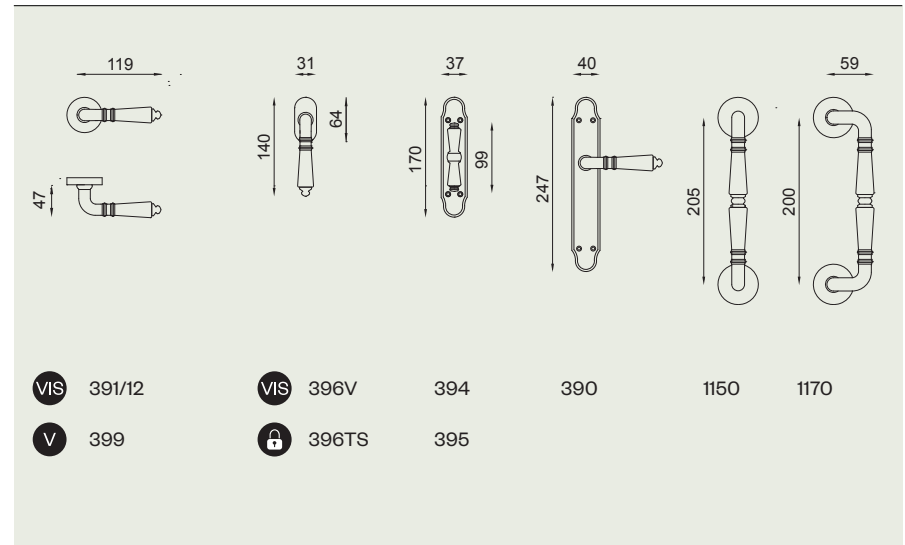

245

daniela porcellana

design: Dnd
technical division

Ottone
Solid brass



OLV+P1
Lucido
Polished



AB+P6
Bronzato
Antique bronze



AF+P6
Anticato
Antique finish



ONV+P1
Nickel lucido
Polished nickel

P1 = Porcellana bianca - White porcelain
P6 = Porcellana avorio - Ivory porcelain

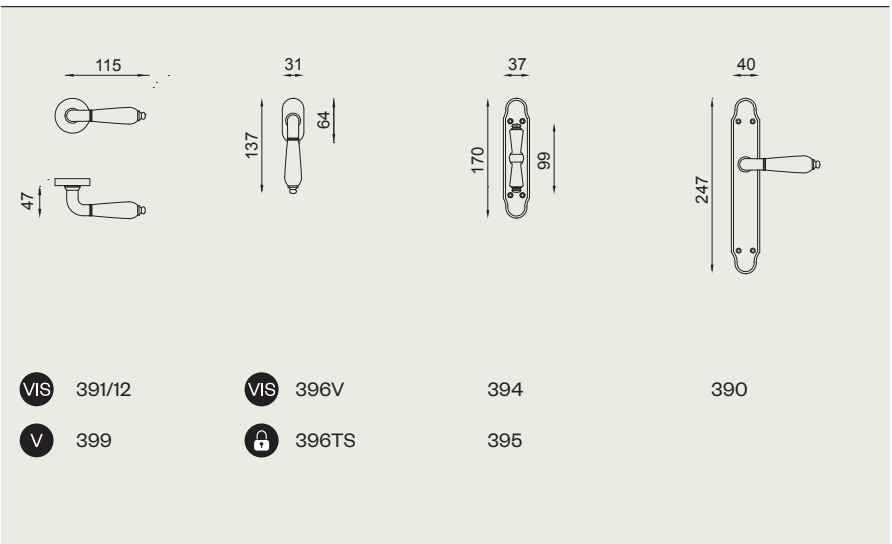

391/12
ONV+P1

246-

dnd 2018/2019

247

beauty

design: Dnd
technical division



775/B
OLV

Ottone
Solid brass



OLV
Lucido
Polished



OGC
Bronzo satinato lucido
Bright satin bronze



AF
Anticato
Antique finish



FAN
Ferro anticato
Antique iron

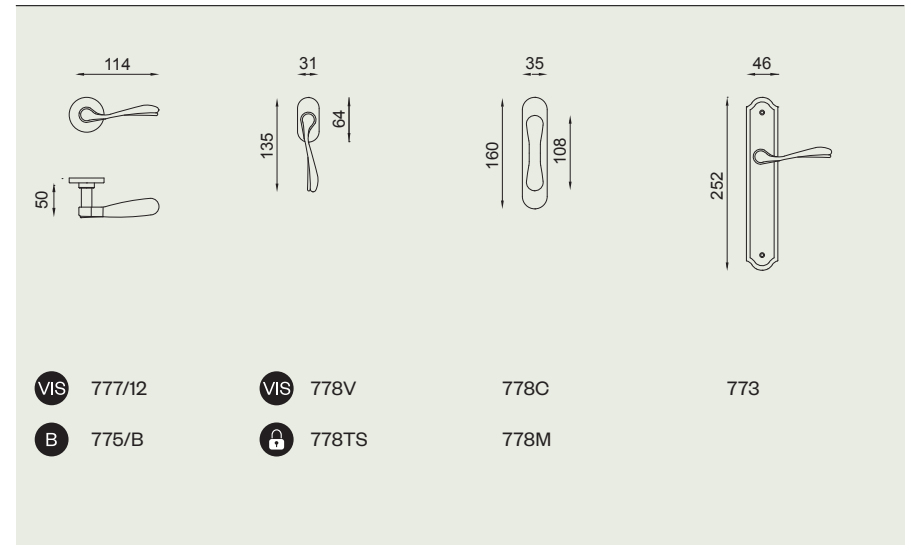

bruxelles

design: Dnd
technical division

Ottone
Solid brass



OLV
Lucido
Polished



AF
Anticato
Antique finish



FAN
Ferro anticato
Antique iron



362/12
FAN

250-

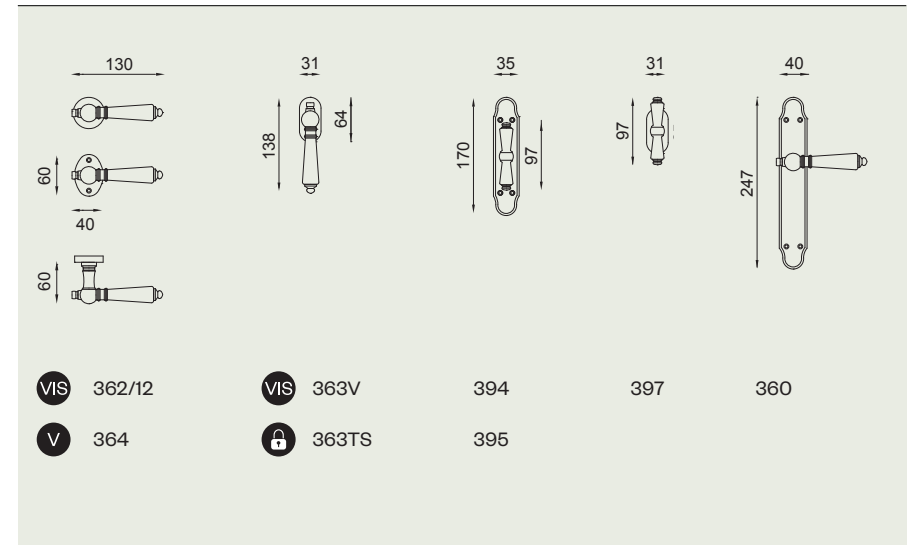

251

katy

design: Dnd
technical division

Ottone
Solid brass



OLV
Lucido
Polished



OGC
Bronzo satinato lucido
Bright satin bronze



AF
Anticato
Antique finish

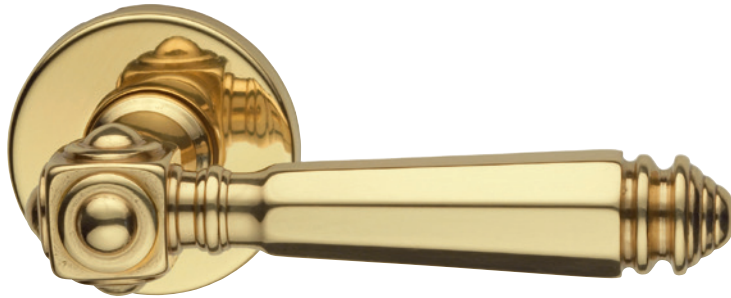

402/12
OLV

252-

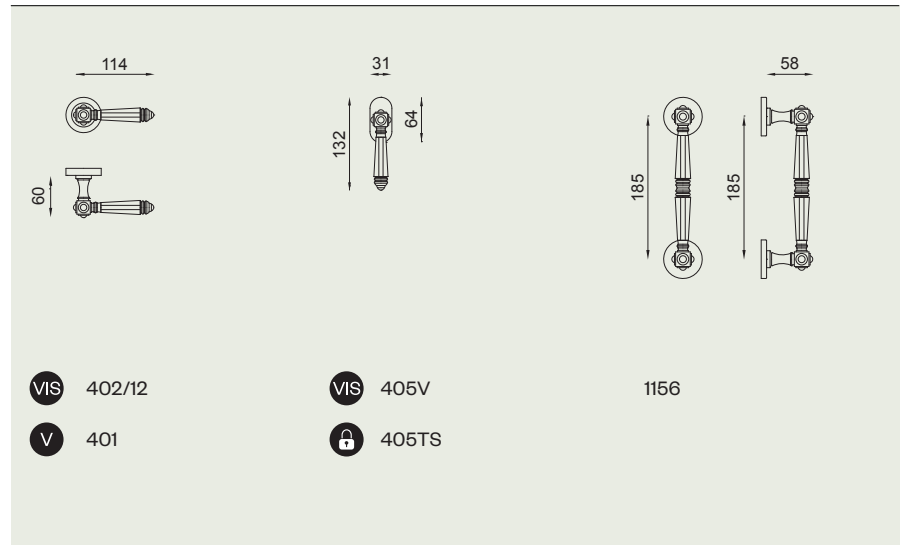

253

dnd 2018/2019

maniglie
professional

handles

– professional

S40

Acciaio inox AISI 316
Stainless steel AISI 316

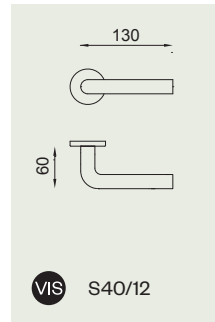

quattro 02 Z

Zama
Zamak



VIS 264/14-Z
ZC

design: Dnd
technical division

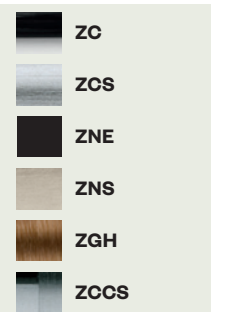

S50

Acciaio inox AISI 316
Stainless steel AISI 316

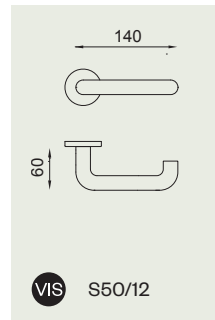

link / link B

Ottone stampato a caldo
Hot stamped brass



VIS 673/12
OLS

design:
Mauro Ronchi

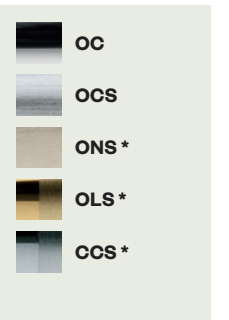

S60

Acciaio inox AISI 316
Stainless steel AISI 316

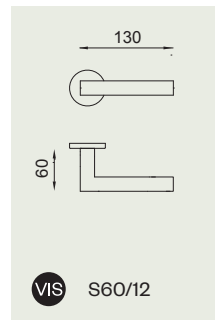

nova / nova B

Ottone stampato a caldo
Hot stamped brass



VIS 663/12
OCS

design:
Mauro Ronchi

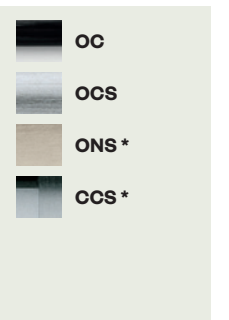

nova 02 / nova B 02

Ottone stampato a caldo
Hot stamped brass

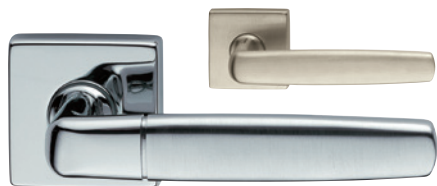

VIS 681/14
OCS

design:
Mauro Ronchi

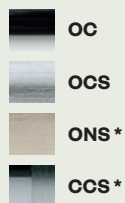

carola

Ottone Zama
Solid brass Zamak

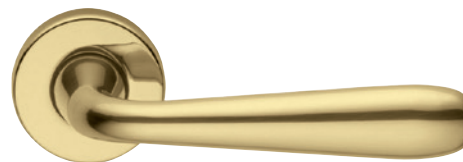

VIS 736/12
OLV

design: Dnd
technical division



tema

Ottone
Solid brass



VIS 162/12
OC

design:
Pietro Silva

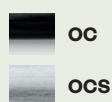

Fino esaurimento scorte - While still in stock

fast

Ottone
Solid brass



VIS 633/12
OC

design:
Mauro Ronchi

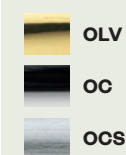

tipo

Ottone
Solid brass



VIS 172/12
OC

design:
Pietro Silva

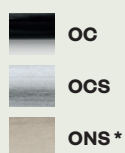

* su ordinazione
on demand

handy

Ottone
Solid brass



VIS 623/12
OLV

design:
Mauro Ronchi

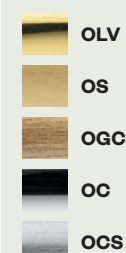

handy 02 Z

Zama
Zamak

design:
Mauro Ronchi

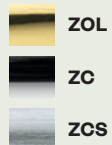

VIS 623/12-Z
ZCS

diana

Ottone
Solid brass

design: Dnd
technical division

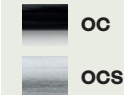

VIS 241/12
OCS

artik

Zama
Zamak

design: Dnd
technical division

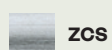

VIS 893/14
ZCS

elena

Ottone
Solid brass

design: Dnd
technical division

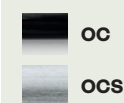

VIS 246/12
OC

noxia

Ottone
Solid brass

design: Dnd
technical division

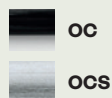

VIS 316/12
OC

Fino esaurimento scorte - While still in stock

arcadia

Ottone
Solid brass

design:
Mauro Ronchi

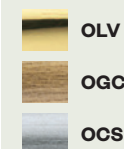

VIS 592/12
OLV

Fino esaurimento scorte - While still in stock

polo

Ottone
Solid brass

design: Dnd
technical division

OLS
CCS



VIS 321/12
OLS

sabina

Ottone Zama
Solid brass Zamak

design: Dnd
technical division

OLV / ZOL
OCS / ZCS
OC



VIS 288/12
OC

venice

Ottone
Solid brass

design: Pietro Silva
CCS

CCS



Fino esaurimento scorte - *While still in stock*

VIS 195/12
CCS

wing

Ottone
Solid brass

design: Dnd
technical division

OLV
OC
OCS



VIS 702/12
OCS

round

Ottone
Solid brass

design: Dnd
technical division

OLS
CCS



Fino esaurimento scorte - *While still in stock*

VIS 714/12
OLS

kristina

Ottone
Solid brass

design: Dnd
technical division

OLV
AF
OCS



VIS 627/12
AF

laura

Ottone
Solid brass



vis 341/12
OCS

design: Dnd
technical division

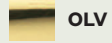

OLV



OGC

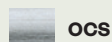

OCS

nina

Ottone
Solid brass



vis 331/12
OCS

design: Dnd
technical division

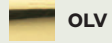

OLV

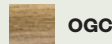

OGC

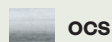

OCS

combinazioni
particolari

– combinations

Kit hotel maniglia-pomolo / Knob-handle hotel kit



OGH
Bronzo satinato opaco
Matt satin bronze

OC
Power cromo lucido
Power polished chrome

PCS
Power cromo satinato
Power satin chrome

PGS
PVD grafite satinato
Satin graphite PVD

ONV
Nickel lucido
Polished nickel

PVX
PVD inox
Steel PVD

ONO
Nero
Black

PVD-BG
PVD oro antico lucido
Antique bright gold PVD

PVD-SG
PVD oro antico satinato
Antique satin gold PVD

Principali soluzioni / Main solutions

Maniglia/ handle
Pomolo / knob

ARETÈ L 02
RING

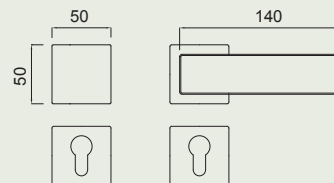

Maniglia/ handle
Pomolo / knob

CHANGE B 02
RING

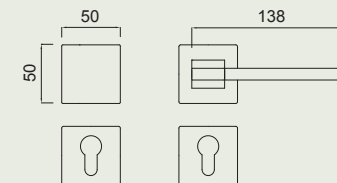

Maniglia/ handle
Pomolo / knob

EDRA 02
RING

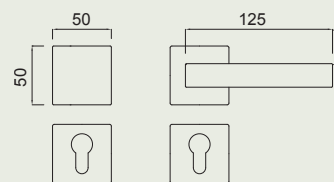

Maniglia/ handle
Pomolo / knob

LUXURY 02
RING

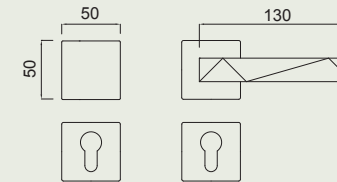

Maniglia/ handle
Pomolo / knob

QUATTRO 02
QUADRO

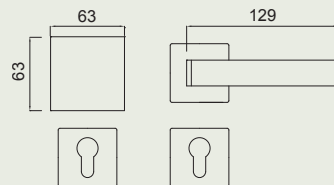

Kit hotel maniglia-pomolo / Knob-handle hotel kit



OGH
Bronzo satinato opaco
Matt satin bronze

OC
Power cromo lucido
Power polished chrome

PCS
Power cromo satinato
Power satin chrome

PGS
PVD grafite satinato
Satin graphite PVD

ONV
Nickel lucido
Polished nickel

PVX
PVD inox
Steel PVD

ONO
Nero
Black

PVD-BG
PVD oro antico lucido
Antique bright gold PVD

PVD-SG
PVD oro antico satinato
Antique satin gold PVD

Principali soluzioni / Main solutions

Maniglia/ handle
Pomolo / knob

TIMELESS
TIMELESS

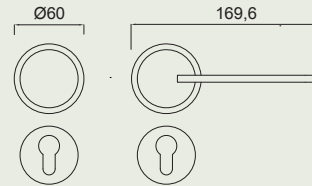

Maniglia/ handle
Pomolo / knob

LUCE
FLUÒ

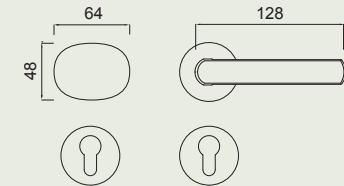

Maniglia/ handle
Pomolo / knob

CHOP
FLUÒ

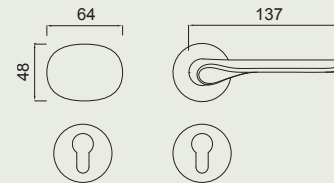

Maniglia/ handle
Pomolo / knob

SAFETY
RONDÒ

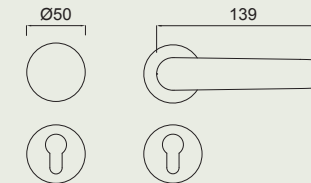

Maniglia/ handle
Pomolo / knob

SHORT
RONDÒ

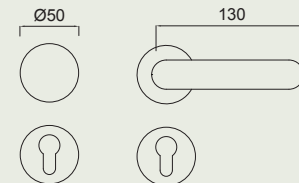

Maniglia/ handle
Pomolo / knob

ART
ART

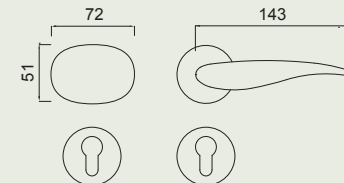

maniglie

per finestre

– windows

handles

aretè

Ottone forgiato
Forged brass

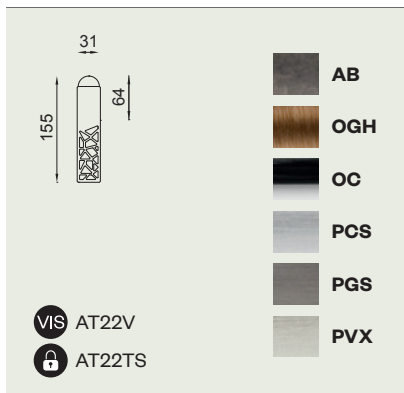

design:
Mauro Ronchi

C-1918

Acciaio inox AISI 316 + rame
AISI Stainless steel 316 + copper

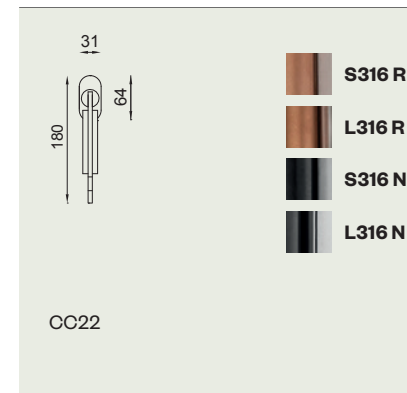

design:
Achille Castiglioni
Gianfranco Cavaglia

aretè 02

Ottone forgiato
Forged brass

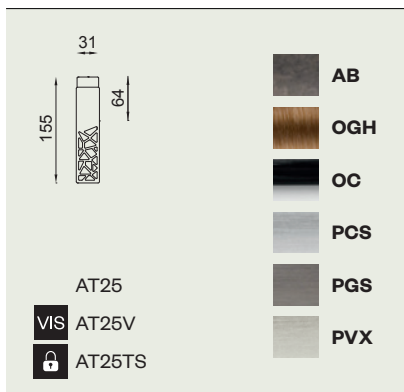

design:
Mauro Ronchi

cloe 02

Ottone stampato a caldo
Hot stamped brass

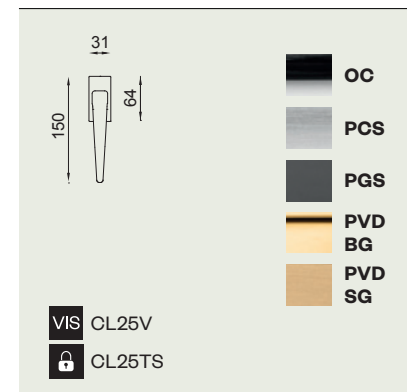

design: Dnd
technical division

change 02

Ottone stampato a caldo
Hot stamped brass

design:
Sandro Santantonio

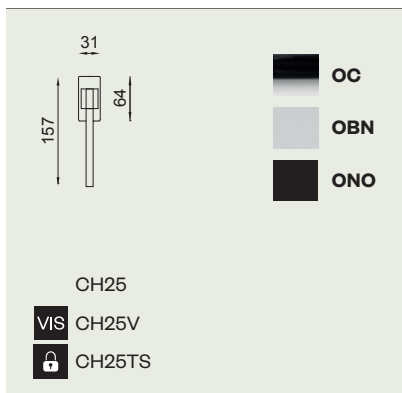

edra 02

Ottone stampato a caldo
Hot stamped brass

design:
Mauro Ronchi

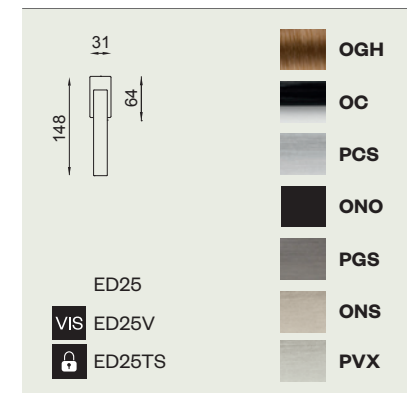

change B02

Ottone stampato a caldo
Hot stamped brass

design:
Sandro Santantonio

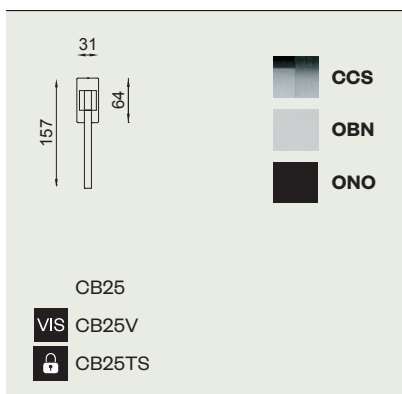

esa due

Alluminio e zama
Aluminium and zamak

design: Dnd
technical division

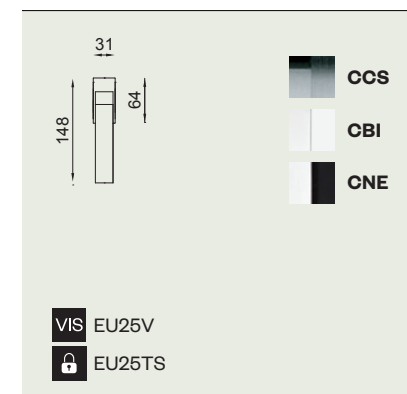

fluke

Ottone stampato a caldo
Hot stamped brass

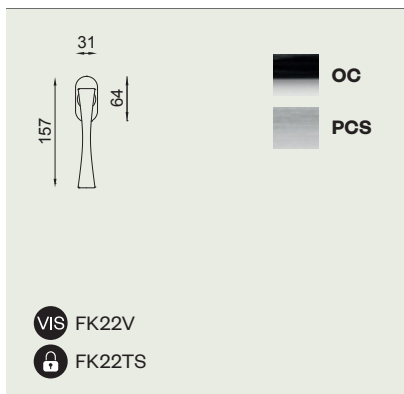

design:
Karim Rashid

ginkgo

Ottone stampato a caldo
Hot stamped brass

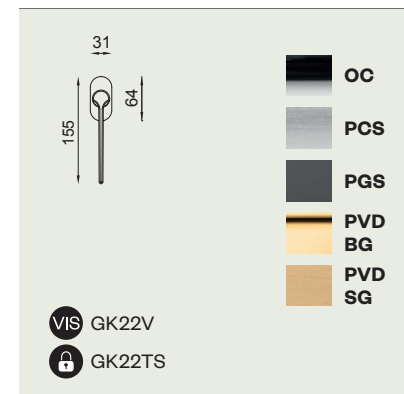

design:
Giulio Iacchetti

luxury 02

Ottone stampato a caldo
Hot stamped brass

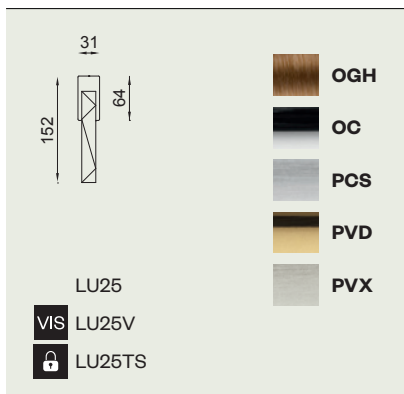

design:
Mauro Ronchi

ginkgo biloba

Ottone stampato a caldo
Hot stamped brass

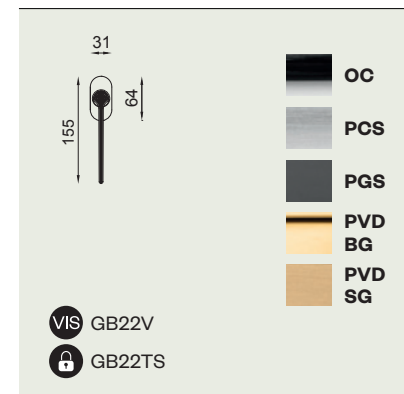

design:
Giulio Iacchetti

isabella

Ottone stampato a caldo
Hot stamped brass

design:
Marco Pisati

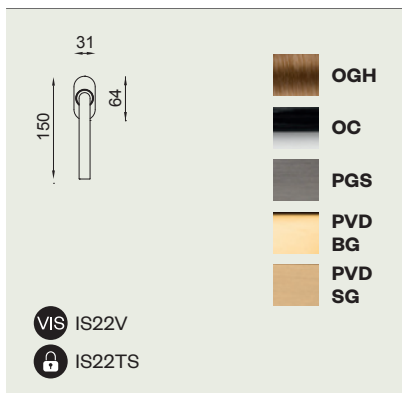

luce

Zama
Zamak

design: Dnd
technical division

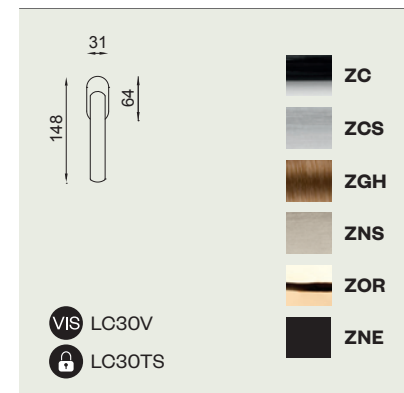

lucrezia

Ottone stampato a caldo
Hot stamped brass

design:
Marco Pisati

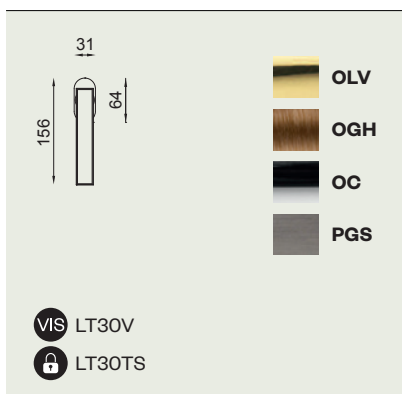

luce 02

Zama
Zamak

design: Dnd
technical division

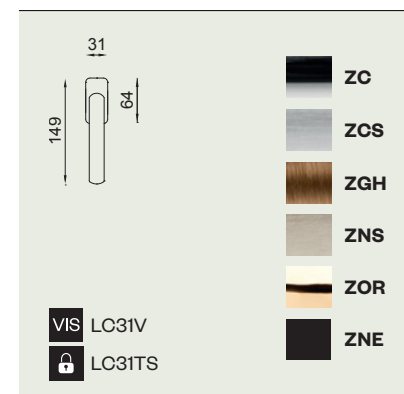

holly

Zama
Zamak

design: Dnd
technical division

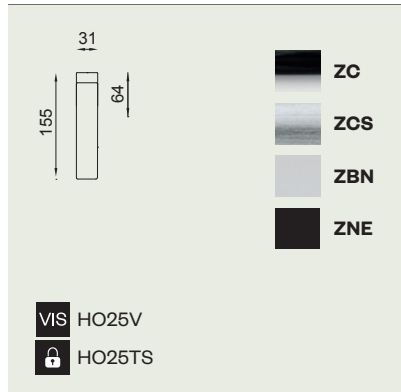

short

Ottone stampato a caldo
Hot stamped brass

design:
Karim Rashid

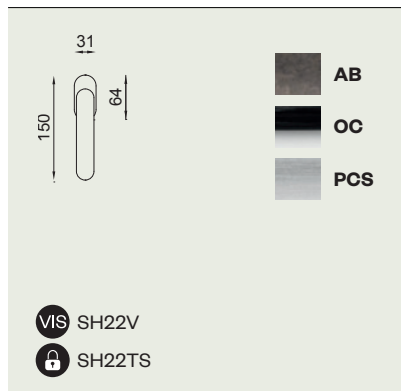

maniglioni

– pull handles

cloe

design: Dnd
technical division

Ottone forgiato
Forged brass

- OC**
Power cromo lucido
Power polished chrome
- PCS**
Power cromo satinato
Power satin chrome
- PGS***
PVD grafite satinato
Satin graphite PVD



* **su ordinazione / on demand**

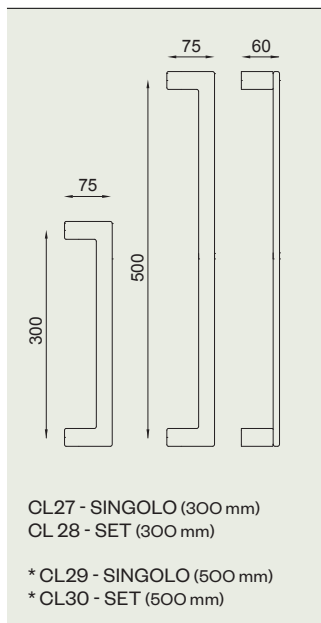

286-

dnd 2018/2019

solid square

design: Dnd
technical division

Ottone forgiato
Forged brass

- OC***
Power cromo lucido
Power polished chrome
- PCS***
Power cromo satinato
Power satin chrome
- PVX***
PVD inox
Steel PVD



* **su ordinazione / on demand**

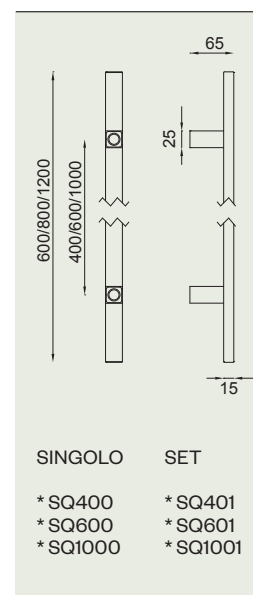

287

solid flat

design: Dnd
technical division

Ottone forgiato
Forged brass

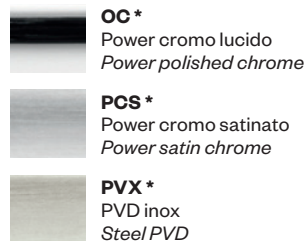

* su ordinazione / on demand

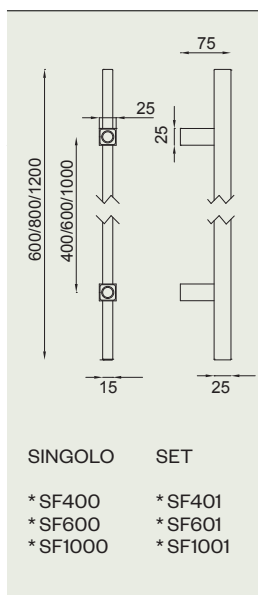

288-



dnd 2018/2019

solid round

design: Dnd
technical division

Ottone forgiato
Forged brass

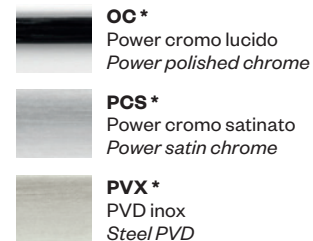

* su ordinazione / on demand

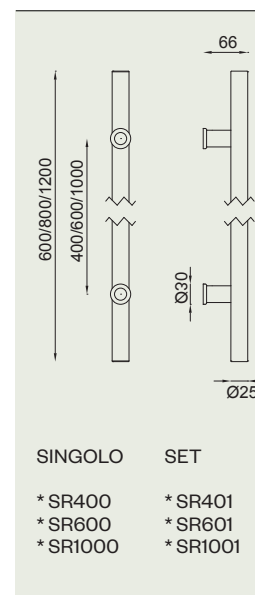

289



aretè

design:
Mauro Ronchi

Ottone forgiato
Forged brass



* **su ordinazione** / *on demand*

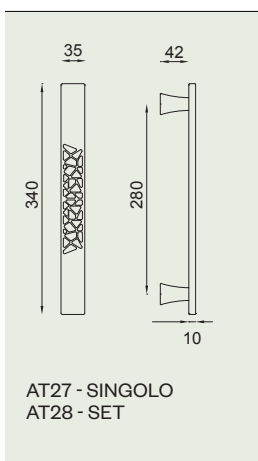

290-

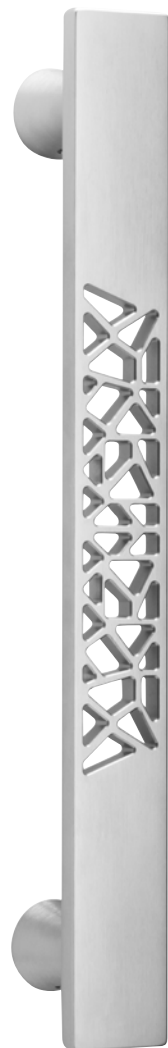

dnd 2018/2019

aretè L

design:
Mauro Ronchi

Ottone forgiato
Forged brass



* **su ordinazione** / *on demand*

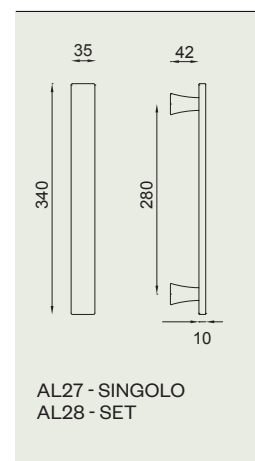

291



luxury

design:
Mauro Ronchi

Ottone stampato a caldo
Hot stamped brass

OGH
Bronzo satinato opaco
Matt satin bronze

OC
Power cromo lucido
Power polished chrome

PCS
Power cromo satinato
Power satin chrome

PGS*
PVD grafite satinato
Satin graphite PVD

PVD-BG*
PVD oro antico lucido
Antique bright gold PVD

PVD-SG*
PVD oro antico satinato
Antique satin gold PVD

* su ordinazione / on demand

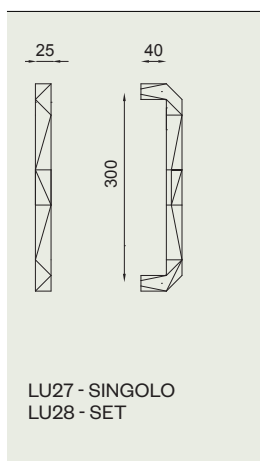

292-



dnd 2018/2019

intake

design:
Andrea Morgante

Ottone forgiato
Forged brass

OC
Power cromo lucido
Power polished chrome

**Altre finiture disponibili
su richiesta.**

*Other finishes available on
demand.*

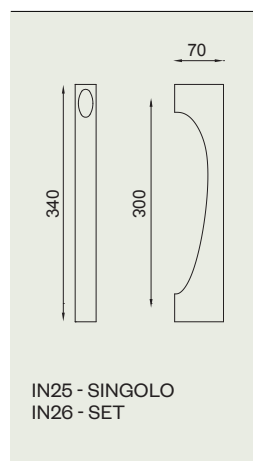

293



C-1918

design:
Achille Castiglioni
Gianfranco Cavaglia

Acciaio inox AISI 316 + rame
AISI Stainless steel 316 + copper

S316 + R
AISI 316 satinato
+ inserto rame PVD
AISI 316 satin
+ PVD copper insert

L316 + R
AISI 316 lucido
+ inserto rame PVD
AISI 316 polished
+ PVD copper insert

S316 + N
AISI 316 satinato
+ inserto rame nero
AISI 316 satin
+ black copper insert

L316 + N
AISI 316 lucido
+ inserto rame nero
AISI 316 polished
+ black copper insert



dnd 2018/2019

C-1918 zancato

design:
Achille Castiglioni
Gianfranco Cavaglia

Acciaio inox AISI 316 + rame
AISI Stainless steel 316 + copper

S316 + R
AISI 316 satinato
+ inserto rame PVD
AISI 316 satin
+ PVD copper insert

L316 + R
AISI 316 lucido
+ inserto rame PVD
AISI 316 polished
+ PVD copper insert

S316 + N
AISI 316 satinato
+ inserto rame nero
AISI 316 satin
+ black copper insert

L316 + N
AISI 316 lucido
+ inserto rame nero
AISI 316 polished
+ black copper insert

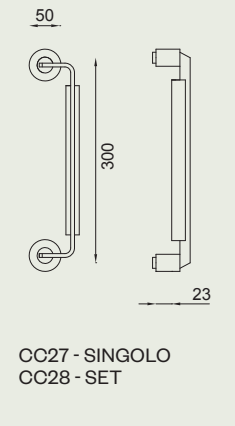

CC27 - SINGOLO
CC28 - SET

295

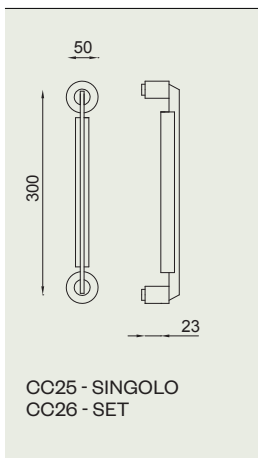

CC25 - SINGOLO
CC26 - SET

294-

luce

design: Dnd
technical division

Zama
Zamak

ZC
Cromo lucido
Polished chrome

ZCS
Cromo satinato
Satin chrome

ZPVD*
PVD oro
Gold PVD



* **su ordinazione** / *on demand*

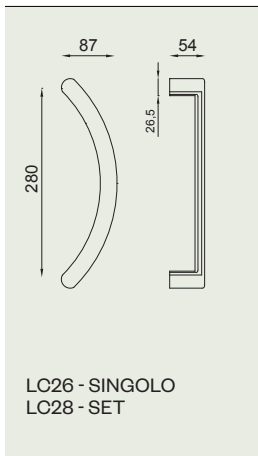

296-

dnd 2018/2019

fluke

design:
Karim Rashid

Ottone stampato a caldo
Hot stamped brass

OC
Power cromo lucido
Power polished chrome

PCS
Power cromo satinato
Power satin chrome

ONS*
Nickel satinato
Satin nickel

PVX*
PVD inox
Steel PVD



* **su ordinazione** / *on demand*

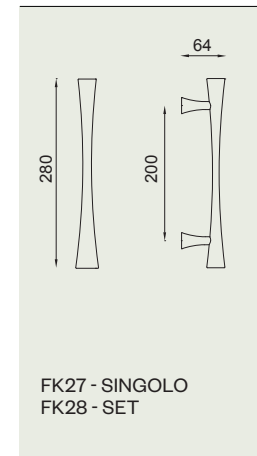

297

project

design: Dnd
technical division

Ottone stampato a caldo
Hot stamped brass

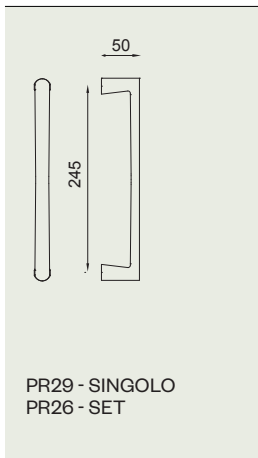

298-

dnd 2018/2019

project spostato

design: Dnd
technical division

Ottone stampato a caldo
Hot stamped brass

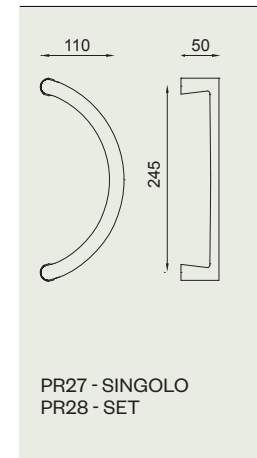

299

ring

design:
Mauro Ronchi

Ottone forgiato
Forged brass

OC
Power cromo lucido
Power polished chrome

PCS
Power cromo satinato
Power satin chrome

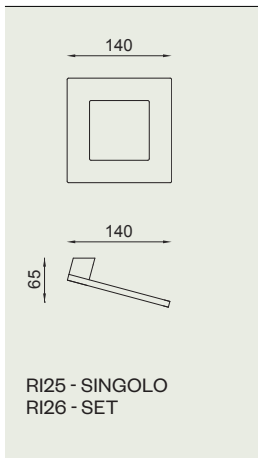

300-

dnd 2018/2019

rondò

design:
Mauro Ronchi

Ottone forgiato
Forged brass

OC
Power cromo lucido
Power polished chrome

PCS
Power cromo satinato
Power satin chrome

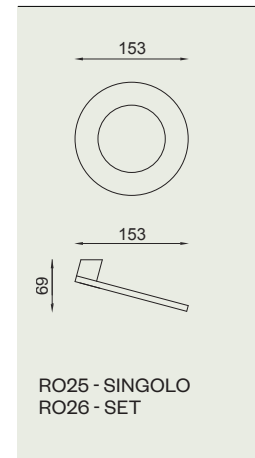

301

logo

Ottone stampato a caldo
Hot stamped brass

design:
Mauro Ronchi

-  **OC**
Power cromo lucido
Power polished chrome
-  **PCS**
Power cromo satinato
Power satin chrome
-  **ONS***
Nickel satinato
Satin nickel
-  **PVX***
PVD inox
Steel PVD

* **su ordinazione** / *on demand*

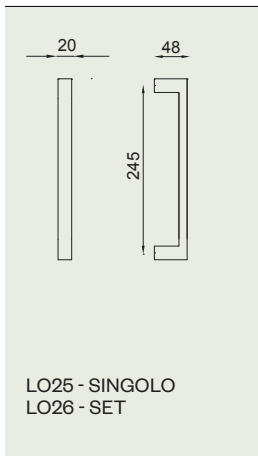

302-



dnd 2018/2019

logo B

Ottone stampato a caldo
Hot stamped brass

design:
Mauro Ronchi

-  **CCS**
Cromo - Power cromo satinato
Chrome - Power satin chrome

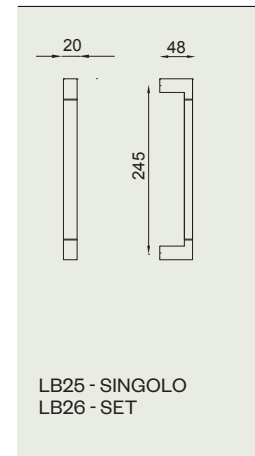

303



linear

design:
Mauro Ronchi

Ottone stampato a caldo
Hot stamped brass

- AB**
Bronzato
Antique bronze
- OGH**
Bronzo satinato opaco
Matt satin bronze
- OC**
Power cromo lucido
Power polished chrome
- PCS**
Power cromo satinato
Power satin chrome

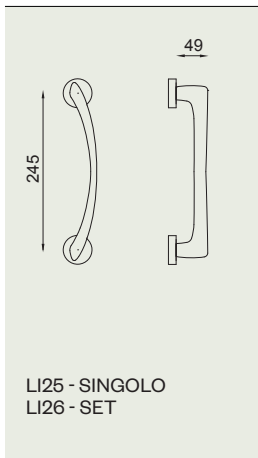

304-

dnd 2018/2019

linear

design:
Mauro Ronchi

Ottone stampato a caldo
Hot stamped brass

- AB**
Bronzato
Antique bronze
- OGH**
Bronzo satinato opaco
Matt satin bronze
- OC**
Power cromo lucido
Power polished chrome
- PCS**
Power cromo satinato
Power satin chrome

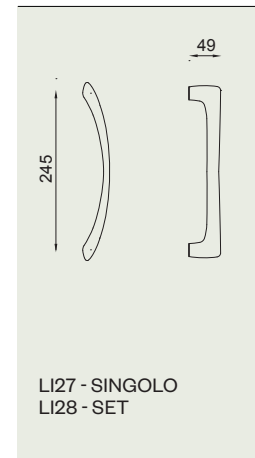

305

art

Ottone stampato a caldo
Hot stamped brass

-  **OGH**
Bronzo satinato opaco
Matt satin bronze
-  **OC**
Power cromo lucido
Power polished chrome
-  **PCS**
Power cromo satinato
Power satin chrome





design:
Mauro Ronchi

dnd 2018/2019

go

Ottone stampato a caldo
Hot stamped brass

-  **OC**
Power cromo lucido
Power polished chrome
-  **PCS**
Power cromo satinato
Power satin chrome

design:
Mauro Ronchi

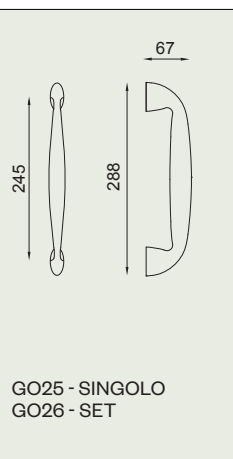

307

306-

domus

design: Dnd
technical division

Ottone
Solid brass



* su ordinazione / on demand

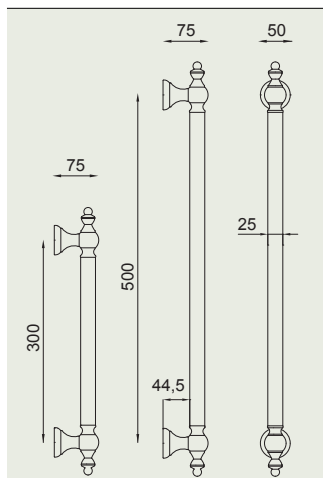

* DO27/300 - SINGOLO
* DO 26/300 - SET
* DO27/500 - SINGOLO
* DO26/500 - SET

308-

dnd 2018/2019

lucrezia

design:
Marco Pisati

Ottone forgiato
Forged brass



* su ordinazione / on demand

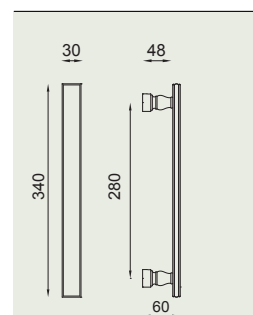

LT27 - SINGOLO
LT28 - SET

309

beverly

design: Dnd
technical division

Ottone stampato a caldo
Hot stamped brass

OLV
Lucido
Polished

OGH
Bronzo satinato opaco
Matt satin bronze

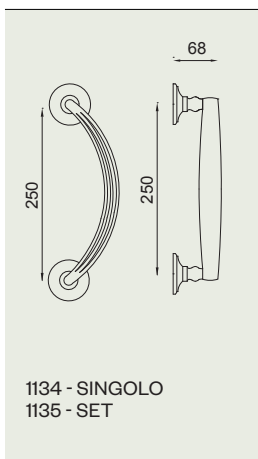

310-

dnd 2018/2019

beverly corto

design: Dnd
technical division

Ottone stampato a caldo
Hot stamped brass

OLV
Lucido
Polished

OGH
Bronzo satinato opaco
Matt satin bronze

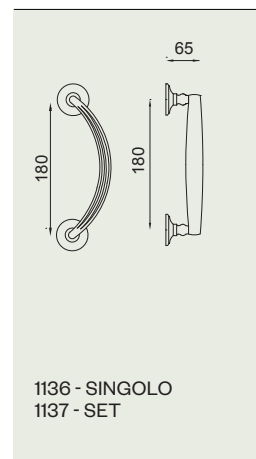

311

lirica

design: Dnd
technical division

Ottone
Solid brass

-  **OLV**
Lucido
Polished
-  **AF**
Anticato
Antique finish
-  **BSS**
Bronzo scuro sfumato
Shaded dark bronze
-  **FAN**
Ferro anticato
Antique iron
-  **ONV***
Nickel lucido
Polished nickel

* **su ordinazione** / on demand

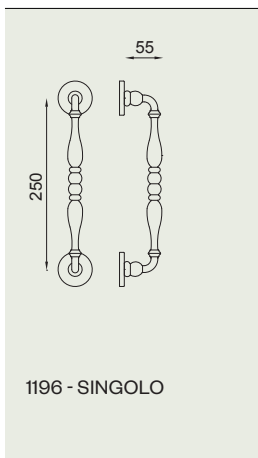

312-



dnd 2018/2019

lirica corto

design: Dnd
technical division

Ottone
Solid brass

-  **OLV**
Lucido
Polished
-  **AF**
Anticato
Antique finish
-  **BSS**
Bronzo scuro sfumato
Shaded dark bronze
-  **FAN**
Ferro anticato
Antique iron
-  **ONV***
Nickel lucido
Polished nickel

* **su ordinazione** / on demand

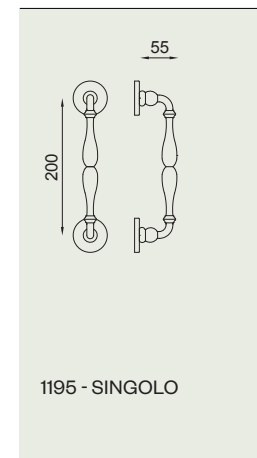





313



daniela

design: Dnd
technical division

Ottone
Solid brass

-  **OLV**
Lucido
Polished
-  **AB**
Bronzato
Antique bronze
-  **AF**
Anticato
Antique finish
-  **FAN**
Ferro anticato
Antique iron
-  **ONV***
Nickel lucido
Polished nickel

* **su ordinazione** / on demand

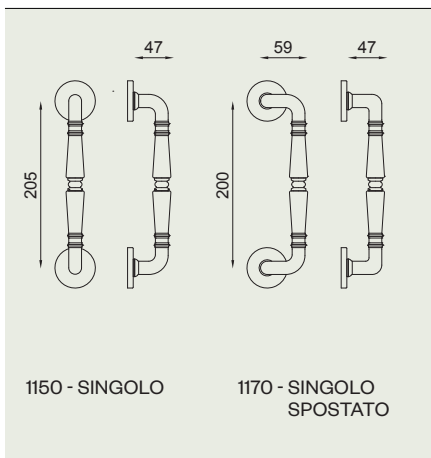

314-



dnd 2018/2019

katy

design: Dnd
technical division

Ottone
Solid brass

-  **OLV***
Lucido
Polished
-  **OGC***
Bronzo satinato lucido
Bright satin bronze
-  **AF***
Anticato
Antique finish

* **su ordinazione** / on demand

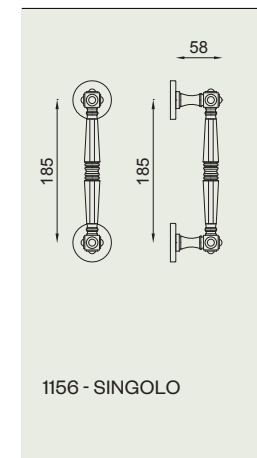

315



latina

design:
Mauro Ronchi

Ottone stampato a caldo
Hot stamped brass

OGH
Bronzo satinato opaco
Matt satin bronze

BSS
Bronzo scuro sfumato
Shaded dark bronze

PVD*
PVD oro
Gold PVD



* **su ordinazione / on demand**

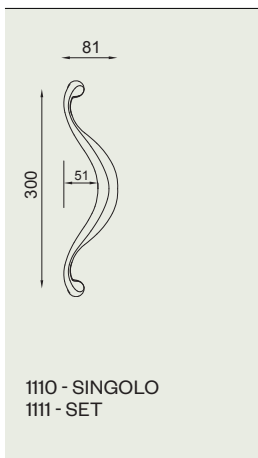

316-

dnd 2018/2019

sabina

design: Dnd
technical division

Ottone
Solid brass

OLV
Lucido
Polished

OC
Power cromo lucido
Power polished chrome

OCS
Cromo satinato
Satin chrome

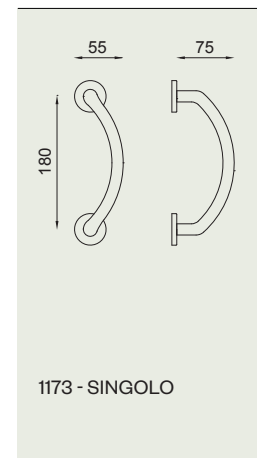

317

only

Ottone
Solid brass

-  **OLV**
Lucido
Polished
-  **AF**
Anticato
Antique finish
-  **OGH**
Bronzo satinato opaco
Matt satin bronze
-  **OCS**
Cromo satinato
Satin chrome



dnd 2018/2019

elena

Ottone
Solid brass

-  **OLV**
Lucido
Polished
-  **OGC**
Bronzo satinato lucido
Bright satin bronze
-  **AF**
Anticato
Antique finish
-  **OCS**
Cromo satinato
Satin chrome
-  **ONS***
Nickel satinato
Satin nickel

design: Dnd
technical division



* **su ordinazione** / *on demand*

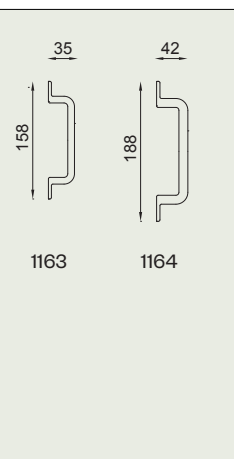

319

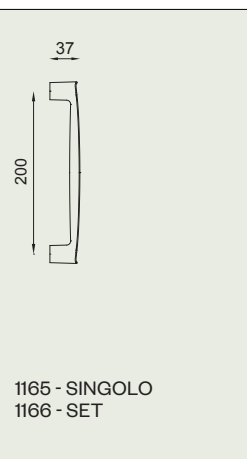

318-

maniglioni

– pull handles
for lift

per alzante
scorrevole

sliding
system

edra

design:
Mauro Ronchi

Ottone stampato a caldo
Hot stamped brass

-  **OGH**
Bronzo satinato opaco
Matt satin bronze
-  **OC**
Power cromo lucido
Power polished chrome
-  **PCS**
Power cromo satinato
Power satin chrome
-  **ONO***
Nero
Black
-  **ONS***
Nickel satinato
Satin nickel
-  **PGS***
PVD grafite satinato
Satin graphite PVD

* **su ordinazione** / on demand

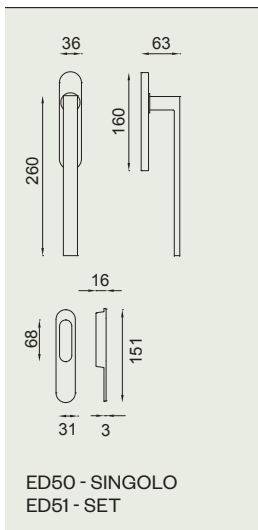

322-





dnd 2018/2019

edra corto

design:
Mauro Ronchi

Ottone stampato a caldo
Hot stamped brass

-  **OC**
Power cromo lucido
Power polished chrome
-  **PCS**
Power cromo satinato
Power satin chrome

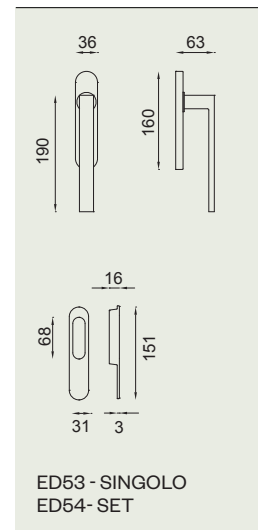

323



edra 02

design:
Mauro Ronchi

Ottone stampato a caldo
Hot stamped brass

- OGH**
Bronzo satinato opaco
Matt satin bronze
- OC**
Power cromo lucido
Power polished chrome
- PCS**
Power cromo satinato
Power satin chrome
- ONO***
Nero
Black
- ONS***
Nickel satinato
Satin nickel
- PGS***
PVD grafite satinato
Satin graphite PVD

* su ordinazione / on demand

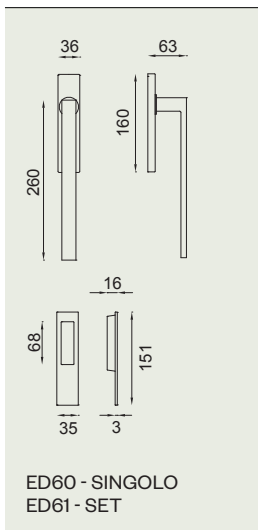

324-



dnd 2018/2019

edra 02 corto

design:
Mauro Ronchi

Ottone stampato a caldo
Hot stamped brass

- OC**
Power cromo lucido
Power polished chrome
- PCS**
Power cromo satinato
Power satin chrome

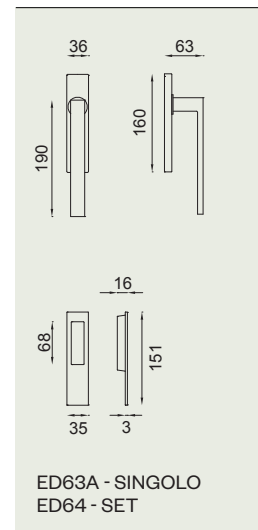

325



luce

design: Dnd
technical division

Zama
Zamak

- ZC**
Cromo lucido
Polished chrome
- ZCS**
Cromo satinato
Satin chrome
- ZGH**
Bronzo satinato opaco
Matt satin bronze
- ZOR***
Placcato oro 24 k
Gold plated 24 k
- ZNS***
Nickel satinato
Satin nickel
- ZNE***
Nero
Black



* su ordinazione / on demand

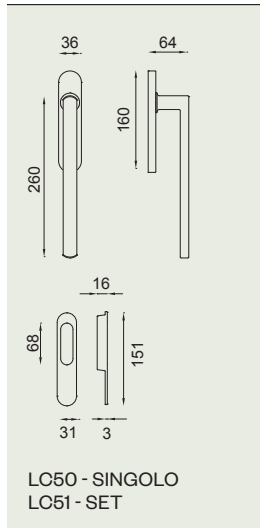

326-

dnd 2018/2019

luce 02

design: Dnd
technical division

Zama
Zamak

- ZC**
Cromo lucido
Polished chrome
- ZCS**
Cromo satinato
Satin chrome
- ZGH**
Bronzo satinato opaco
Matt satin bronze
- ZNS***
Nickel satinato
Satin nickel
- ZNE***
Nero
Black

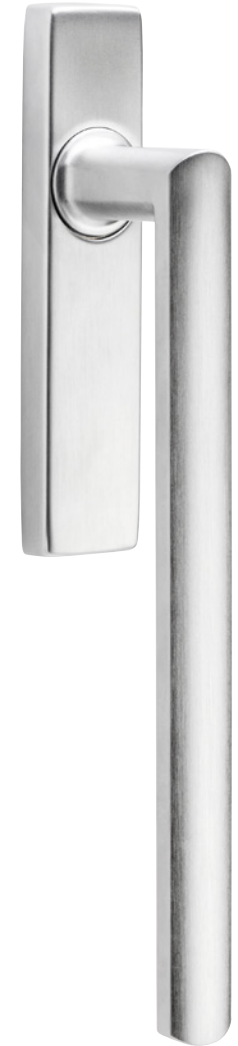

* su ordinazione / on demand

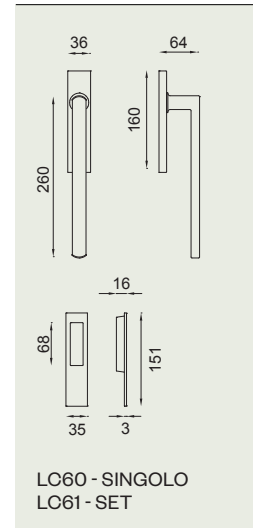

327

slide

design:
Mauro Ronchi

Ottone stampato a caldo
Hot stamped brass



* su ordinazione / on demand

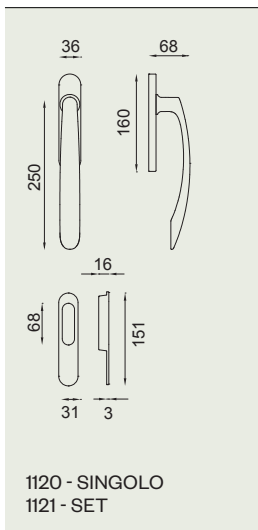

328-

dnd 2018/2019

slide corto

design:
Mauro Ronchi

Ottone stampato a caldo
Hot stamped brass

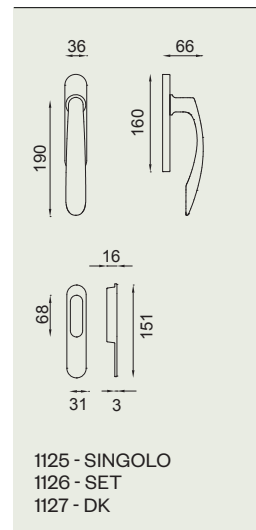
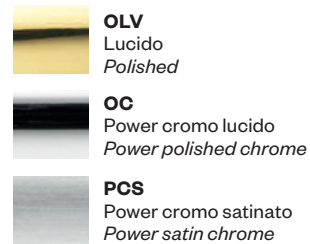

329

liter

design: Dnd
technical division

Ottone
Brass

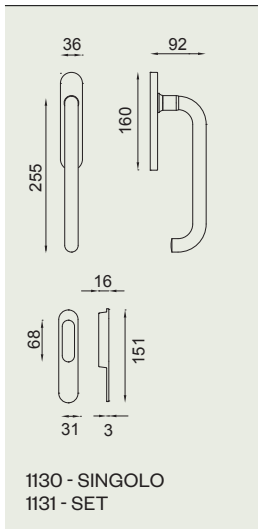

330-

dnd 2018/2019

nicchie

Ottone stampato a caldo
Hot stamped brass

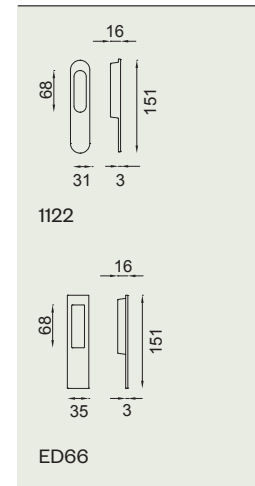

331

pomoli

– knobs

lucrezia

design:
Marco Pisati

Ottone forgiato
Forged brass

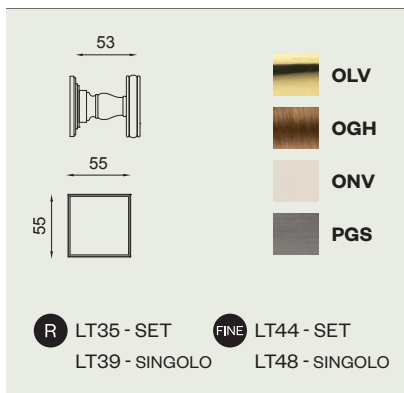

ring

design: Dnd
technical division

Ottone forgiato
Forged brass

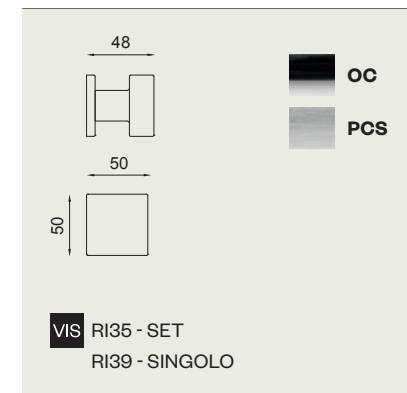

lucrezia 02

design:
Marco Pisati

Ottone forgiato
Forged brass

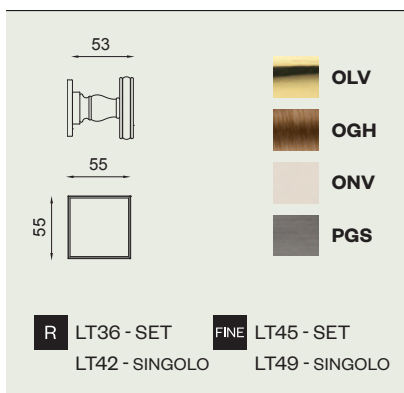

rondò

design: Dnd
technical division

Ottone forgiato
Forged brass

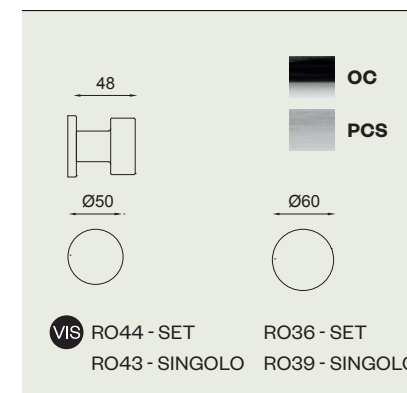

fluò

Ottone
Solid brass

design:
Mauro Ronchi

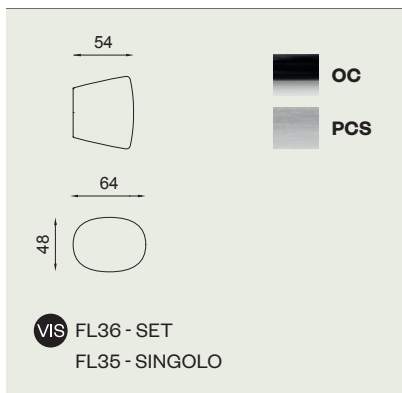

go

Ottone
Solid brass

design:
Mauro Ronchi

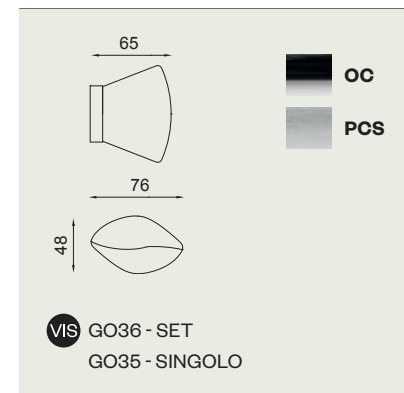

art

Ottone
Solid brass

design:
Mauro Ronchi

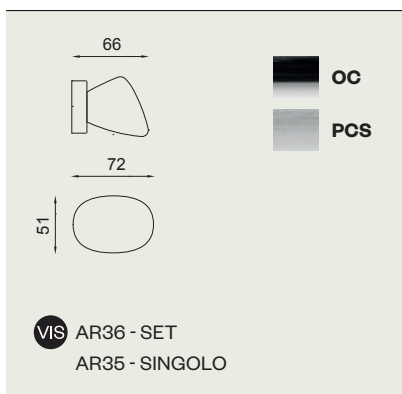

easy

Ottone
Solid brass

design: Dnd
technical division

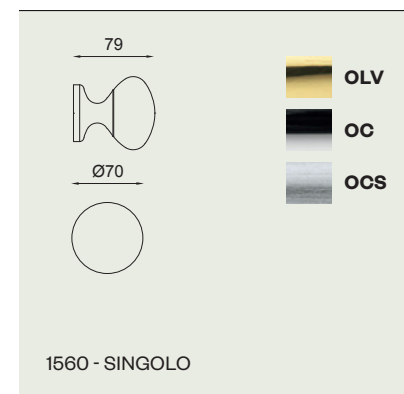

timeless

design:
Marco Pisati

Alluminio
Aluminium



quadro

design: Dnd
technical division

Ottone
Solid brass

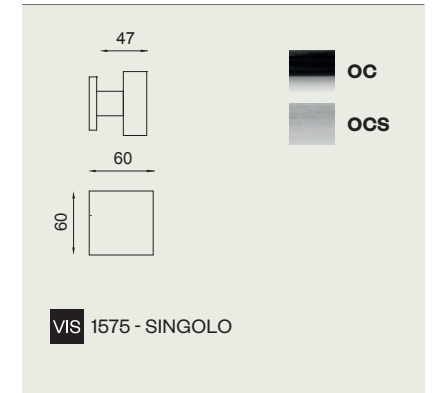

project

design: Dnd
technical division

Ottone
Solid brass

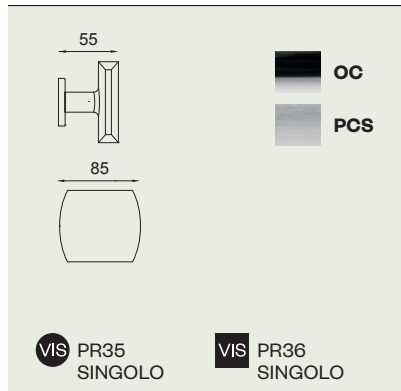

sfera

design: Dnd
technical division

Ottone
Solid brass

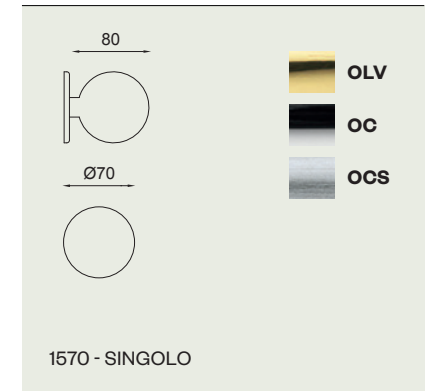

fiorenza

Ottone stampato a caldo
Hot stamped brass

design: Dnd
technical division

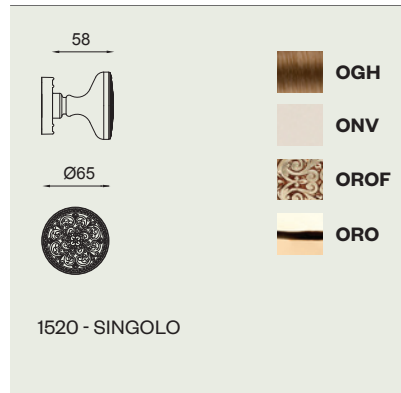

victorian

Ottone
Solid brass

design: Dnd
technical division

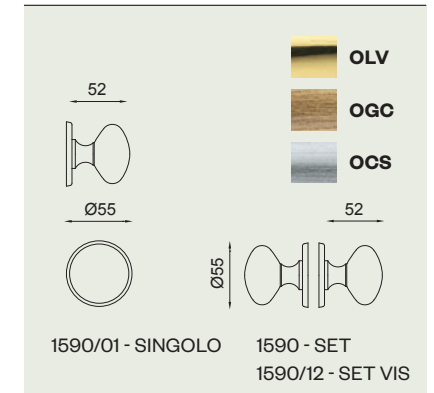

diamante

Ottone
Solid brass

design: Dnd
technical division

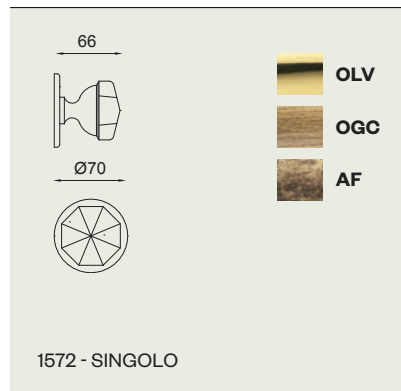

ovale centrale





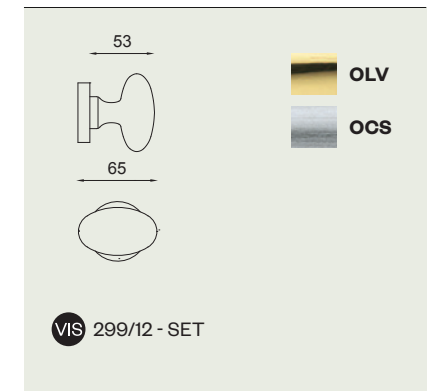

Ottone
Solid brass

design: Dnd
technical division

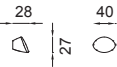

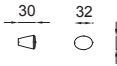
pomolini per mobili furniture knobs

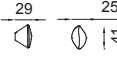
Ottone
Solid brass

		AR40 ART
		FL40 FLUÒ
		GO40 GO
		1636 Ø 25-32 VICTORIAN
		1635 Ø 25-32-50 GEORGIAN

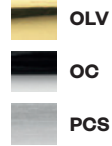

lucrezia: accessori per mobili lucrezia: furniture accessories

design:
Marco Pisati

Ottone forgiato
Forged brass

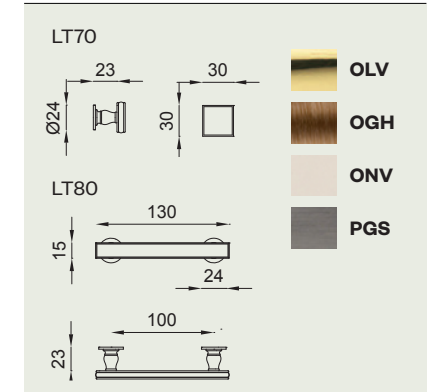

maniglie

– sliding
door

per porte
scorrevoli

handles

ginkgo tonda

design:
Giulio Iacchetti

Ottone e zama
Brass and zamak

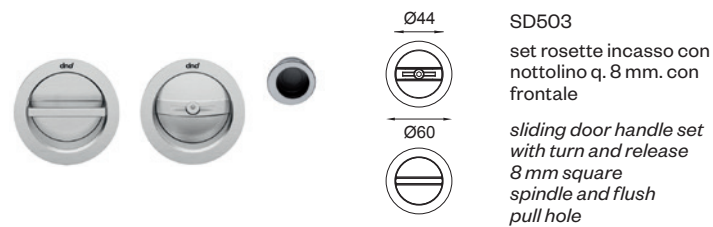
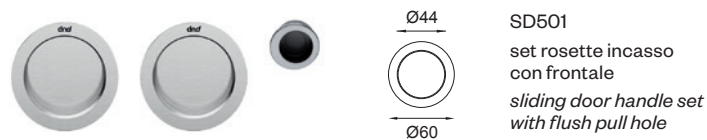
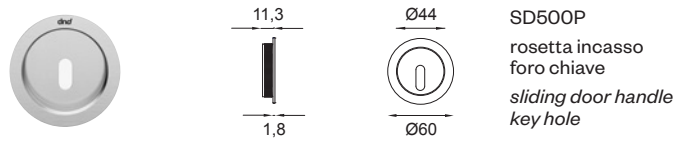
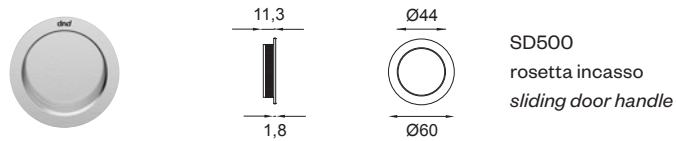
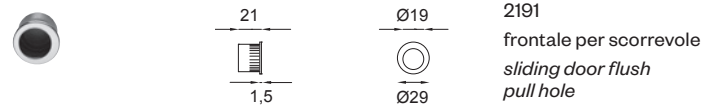

ginkgo tonda

design:
Giulio Iacchetti

Ottone e zama
Brass and zamak

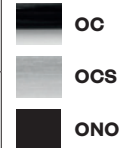
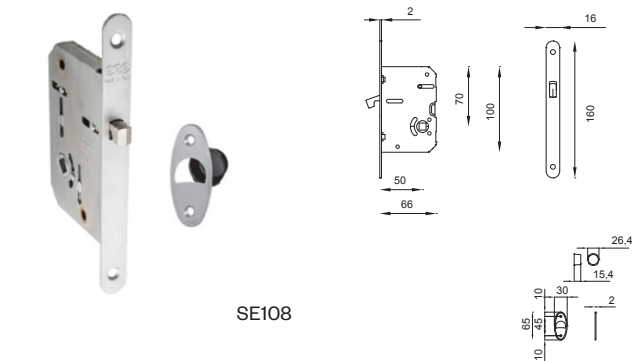
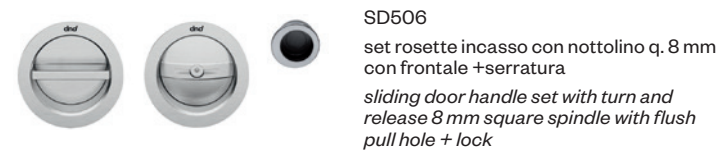
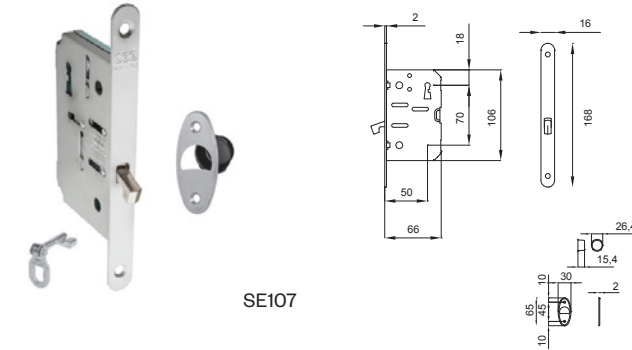
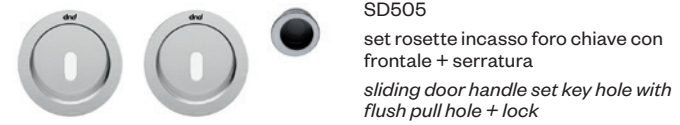

ginkgo quadra

design:
Giulio Iacchetti

Ottone e zama
Brass and zamak

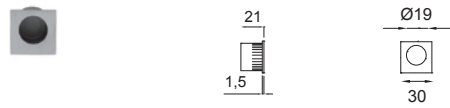

2189
frontale per scorrevole
*sliding door flush
pull hole*

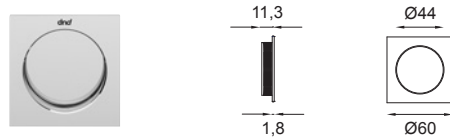

SD520
rosetta incasso
sliding door handle

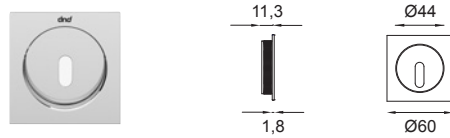

SD520P
rosetta incasso
foro chiave
*sliding door handle
key hole*



SD521
set rosette incasso
con frontale
*sliding door handle set
with flush pull hole*



SD523
set rosette incasso con
nottolino q.8 mm. con
frontale
*sliding door handle set
with turn and release
8 mm square
spindle and flush
pull hole*

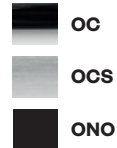

ginkgo quadra

design:
Giulio Iacchetti

Ottone e zama
Brass and zamak

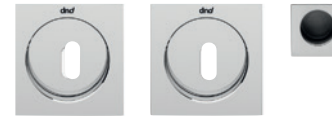

SD525
set rosette incasso foro chiave con
frontale + serratura
*sliding door handle set key hole with
flush pull hole + lock*



SE107

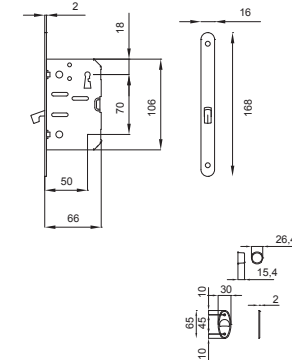

SD526
set rosette incasso con nottolino q.8 mm
con frontale + serratura
*sliding door handle set with turn and
release 8 mm square spindle with flush
pull hole + lock*



SE108

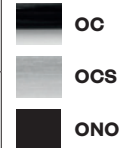
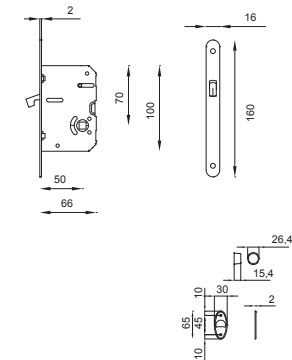

Ottone
Solid brass

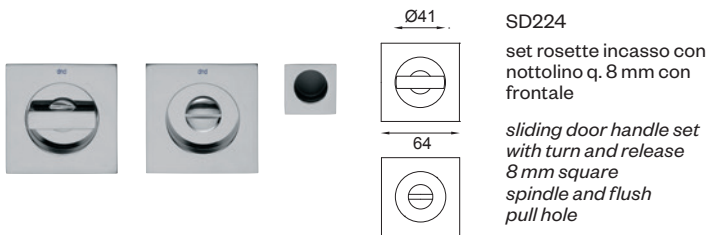
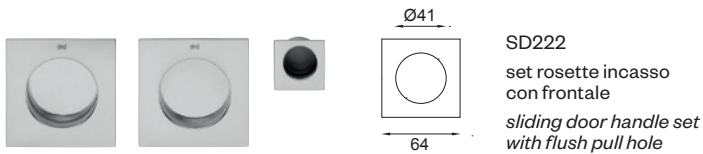
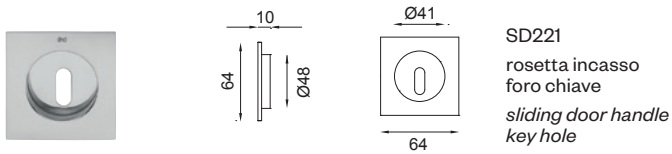
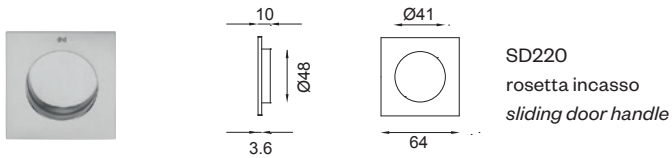
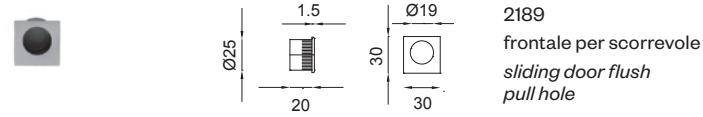

*su ordinazione
on demand

Ottone
Solid brass

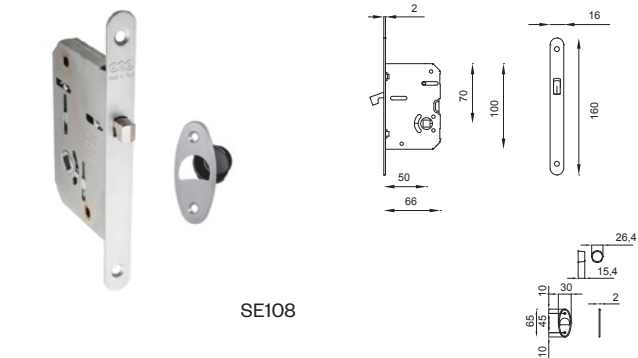
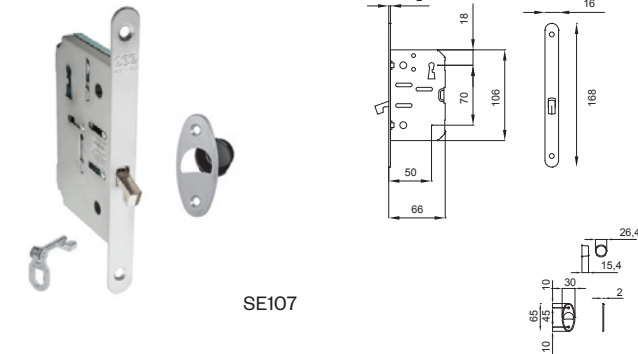
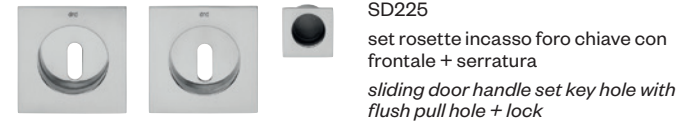

*su ordinazione
on demand

rondò

design: Dnd
technical division

Ottone
Solid brass

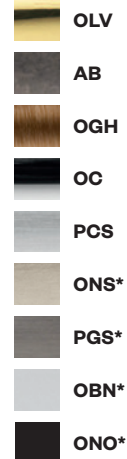
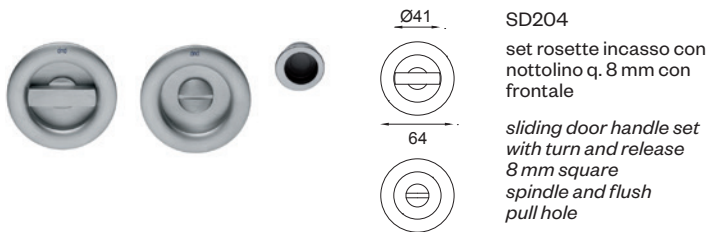
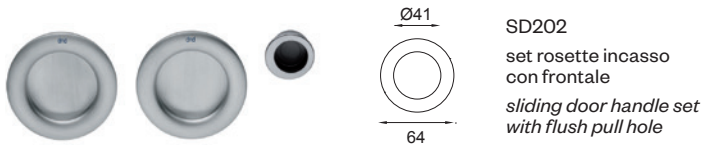
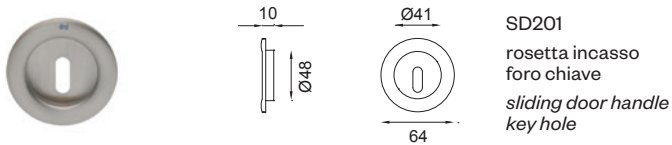
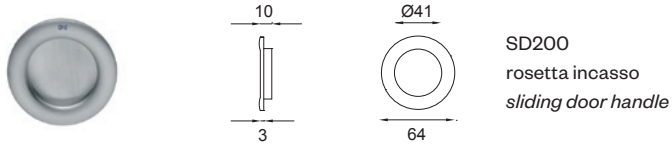
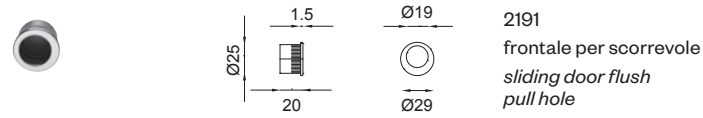

* su ordinazione
on demand

rondò

design: Dnd
technical division

Ottone
Solid brass

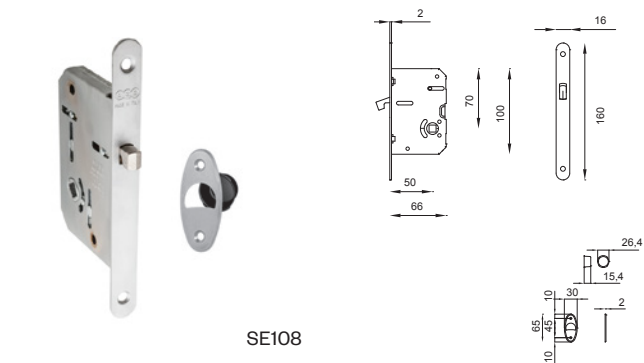
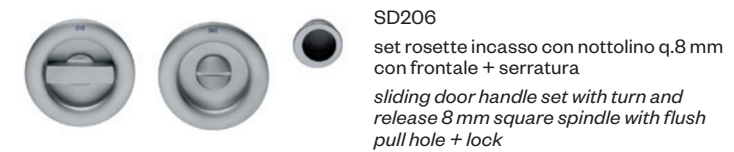
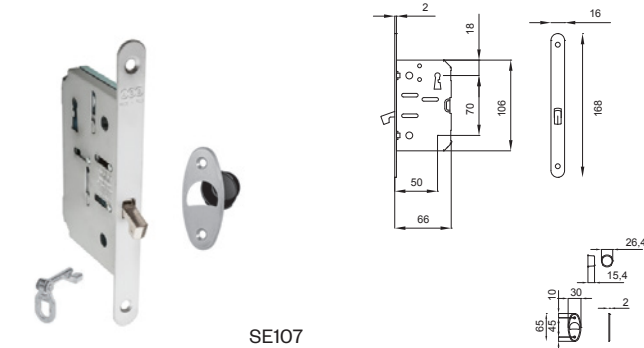
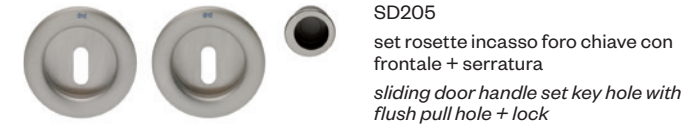

* su ordinazione
on demand

quadra

design: Dnd
technical division

Ottone
Solid brass

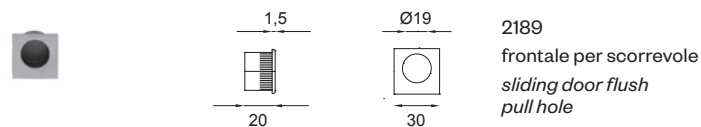

2189
frontale per scorrevole
*sliding door flush
pull hole*

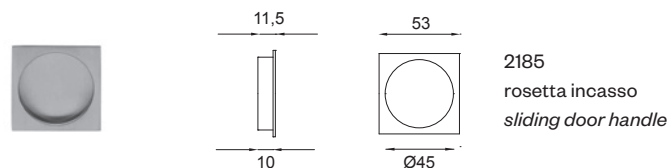

2185
rosetta incasso
sliding door handle

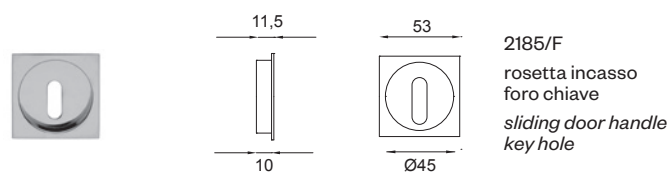

2185/F
rosetta incasso
foro chiave
*sliding door handle
key hole*

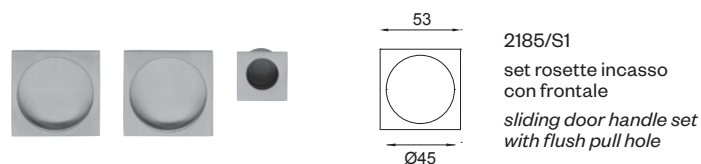

2185/S1
set rosette incasso
con frontale
*sliding door handle set
with flush pull hole*

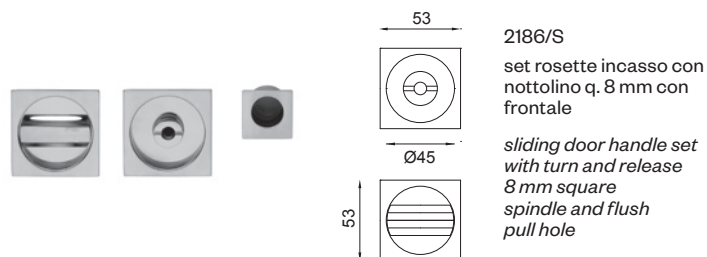

2186/S
set rosette incasso con
nottolino q. 8 mm con
frontale
*sliding door handle set
with turn and release
8 mm square
spindle and flush
pull hole*

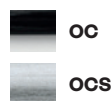

quadra

design: Dnd
technical division

Ottone
Solid brass



2185/SE107
set rosette incasso foro chiave
con frontale + serratura
*sliding door handle set key hole with
flush pull hole + lock*



SE107

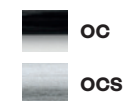
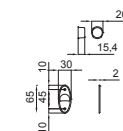
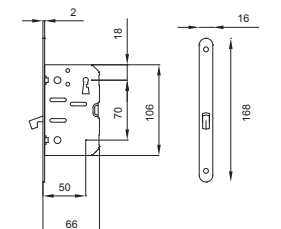

2186/SE108
set rosette incasso con nottolino q.8 mm
con frontale + serratura
*sliding door handle set with turn and
release 8 mm square spindle with flush
pull hole + lock*





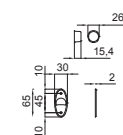
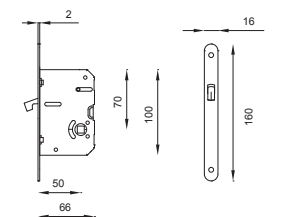





SE108

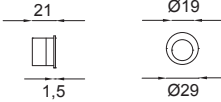

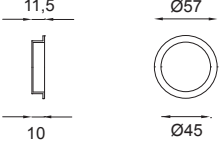
tonda

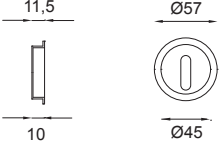
design: Dnd
technical division

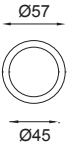
Ottone
Solid brass

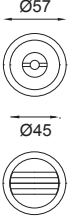

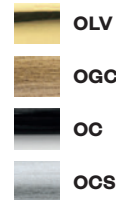
		2191 frontale per scorrevole <i>sliding door flush pull hole</i>
		2193 rosetta incasso <i>sliding door handle</i>
		2193/F rosetta incasso foro chiave <i>sliding door handle key hole</i>
		2193/S1 set rosette incasso con frontale <i>sliding door handle set with flush pull hole</i>
		2194/S set rosette incasso con nottolino q. 8 mm con frontale <i>sliding door handle set with turn and release 8 mm square spindle and flush pull hole</i>



tonda

design: Dnd
technical division

Ottone
Solid brass

	2193/SE107 set rosette incasso foro chiave con frontale + serratura <i>sliding door handle set key hole with flush pull hole + lock</i>
	2194/SE108 set rosette incasso con nottolino q.8 mm con frontale + serratura <i>sliding door handle set with turn and release 8 mm square spindle with flush pull hole + lock</i>

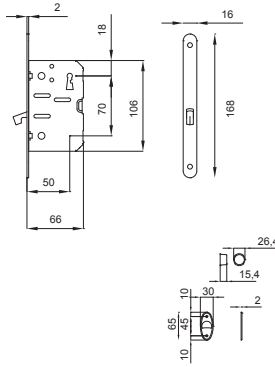

SE107

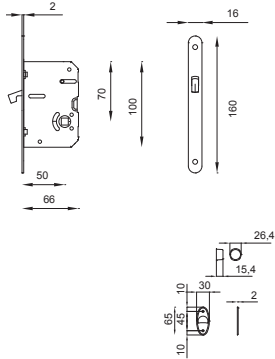

SE108



rettangolare

design: Dnd
technical division

Ottone
Brass

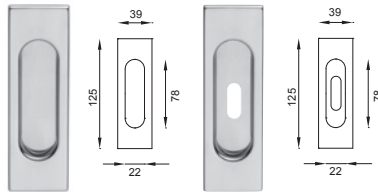

2187
placchetta incasso coprivite
*sliding door handle
concealed fixing*

2187/F
placchetta incasso coprivite
con foro chiave
*sliding door handle key hole
concealed fixing*



2187/S1
set placchette incasso con
frontale
*sliding door handle set with
flush pull hole*



2187/SE107
set placchette incasso foro
chiave con frontale
+ serratura
*sliding door handle set
key hole with flush pull hole
+ lock*

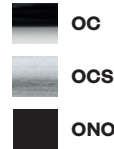

2187/S
set placchette incasso con
nottolino q. 8 mm e frontale
*sliding door handle set with
turn and release 8 mm square
spindle and flush pull hole*



2187/SE108
set placchette incasso con
nottolino q. 8 mm con frontale
e serratura
*sliding door handle set with
turn and release 8 mm sq.
spindle with flush pull hole
+ lock*

noxia

design: Dnd
technical division

Ottone
Brass

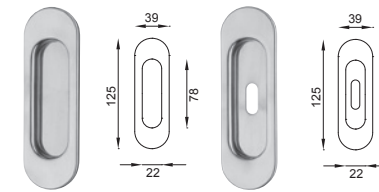

2197
placchetta incasso coprivite
*sliding door handle
concealed fixing*

2197/F
placchetta incasso coprivite
con foro chiave
*sliding door handle key hole
concealed fixing*



2197/S1
set placchette incasso con
frontale
*sliding door handle set with
flush pull hole*



2197/SE107
set placchette incasso foro
chiave con frontale
+ serratura
*sliding door handle set
key hole with flush pull hole
+ lock*



2197/S
set placchette incasso con
nottolino q. 8 mm e frontale
*sliding door handle set with
turn and release 8 mm square
spindle and flush pull hole*



2197/SE108
set placchette incasso con
nottolino q. 8 mm con frontale
e serratura
*sliding door handle set with
turn and release 8 mm sq.
spindle with flush pull hole
+ lock*

serrature per porte scorrevoli *locks for sliding door handles*



SE107
serratura con chiave snodata
lock with jointed key

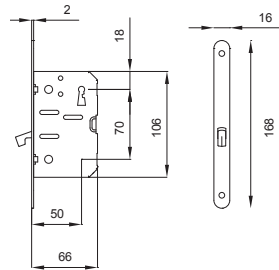

SE108
serratura con foro quadro 8mm
lock with 8 mm square hole

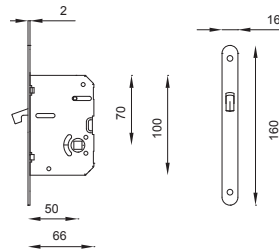

articoli

vari

– other
complements

ring

Ottone forgiato
Forged brass



design:
Mauro Ronchi

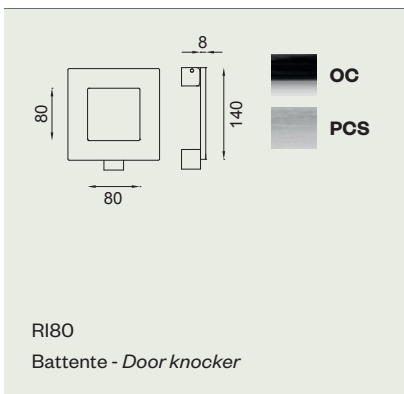

anello

Ottone
Solid brass



design: Dnd
technical division

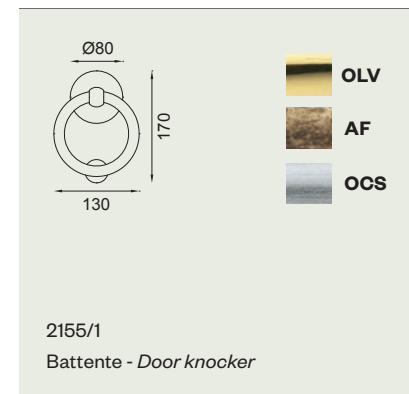

rondò

Ottone forgiato
Forged brass



design:
Mauro Ronchi

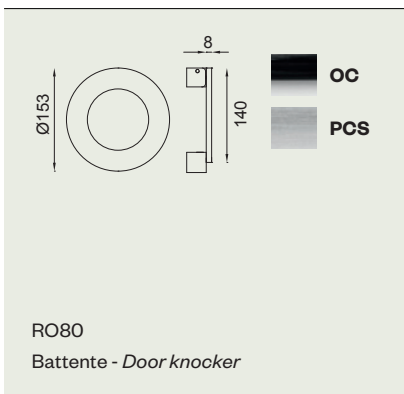

alga

Ottone stampato a caldo
Hot stamped brass



design:
Mauro Ronchi

su ordinazione / on demand

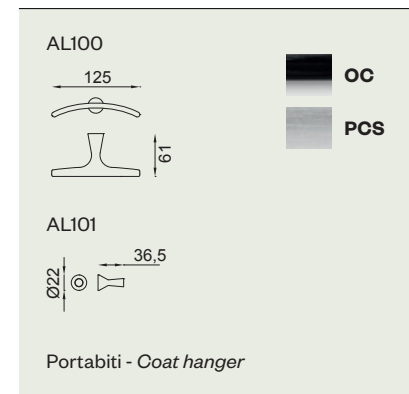

medusa

Ottone stampato a caldo
Hot stamped brass

design:
Mauro Ronchi

su ordinazione / on demand

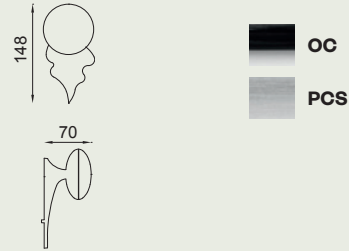

ME100
Portabiti - Coat hanger

moby

Ottone stampato a caldo
Hot stamped brass

design:
Mauro Ronchi

su ordinazione / on demand

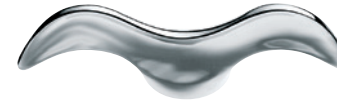

MO100
Portabiti - Coat hanger

medusa rigato

Ottone stampato a caldo
Hot stamped brass

design:
Mauro Ronchi

su ordinazione / on demand

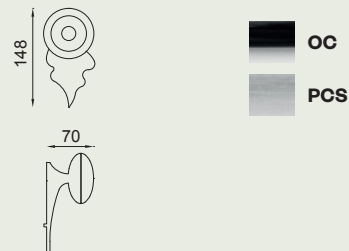

ME101
Portabiti - Coat hanger

loto

Ottone stampato a caldo
Hot stamped brass

design:
Mauro Ronchi

su ordinazione / on demand

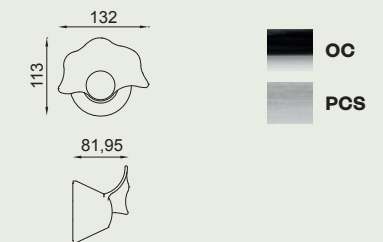

LO100
Portabiti - Coat hanger

nottolino dnd dnd turn & release

design:
Mauro Ronchi

ottone
solid brass

finiture / finishes:
OLV OS AB OGH OC
PCS ONS PGS PVD PVX
OBN ONO



NODN1
nottolino Dnd
Dnd turn & release



VIS **RDN08+A**
set nottolino su rosetta
turn & release set on rose
50x7mm - VIS

52 **RDN03+A**
set nottolino su rosetta
turn & release set on rose
52x10mm - 52



FINE **RDN44+A**
set nottolino su rosetta
turn & release set on rose
50x4mm - FINE

FINE **RDN45+A**
set nottolino su rosetta
turn & release set on rose
50x4mm - FINE



VIS **RDN09+A**
set nottolino su rosetta quadra
turn & release set on square rose
50x7mm - VIS

52 **RDN05+A**
set nottolino su rosetta quadra
smussata / turn & release set on
chamfered square rose
52x10mm - 52



R **RDN18+A**
set nottolino su rosetta
turn & release set on rose
45x50mm - ARDEA

R **RDN19+A**
set nottolino su rosetta
turn & release set on rose
50x60mm - CASSIA

nottolino logo logo turn & release

design:
Mauro Ronchi

ottone
solid brass

finiture / finishes:
OLV OS AB OGH OC
PCS ONS PGS PVD PVX
OBN ONO



NODN10
nottolino logo
logo turn & release



VIS **RDN12+A / RDN 12X+A (Inox)**
set nottolino su rosetta
turn & release set on rose
50x7mm - VIS

52 **RDN13+A**
set nottolino su rosetta
turn & release set on rose
52x10mm - 52



FINE **RDN40+A**
set nottolino su rosetta
turn & release set on rose
50x4mm - FINE



VIS **RDN14+A**
set nottolino su rosetta quadra
turn & release set on square rose
50x7mm - VIS

52 **RDN15+A**
set nottolino su rosetta quadra
turn & release set on square rose
52x10mm - 52



FINE **RDN41+A**
set nottolino su rosetta
turn & release set on rose
50x4mm - FINE

nottolino lucrezia

lucrezia turn & release

design:
Marco Pisati

ottone
solid brass

finiture / finishes:
OLV OGH ONV PGS

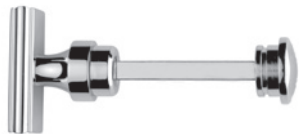

NODN30
nottolino lucrezia
lucrezia turn & release



R **RDN30+A**
set nottolino su rosetta
turn & release set on rose
50x6mm - LUCREZIA

FINE **RDN31+A**
set nottolino su rosetta
turn & release set on rose
50x4mm - FINE



R **RDN33+A**
set nottolino su rosetta
turn & release set on rose
50x6mm - LUCREZIA

FINE **RDN32+A**
set nottolino su rosetta
turn & release set on rose
50x4mm - FINE

nottolino timeless

timeless turn & release

design:
Marco Pisati

Alluminio
Aluminium

finiture / finishes:
ASV ARO ABR ABN ANE



FINE **RDN50+A**
set nottolino su rosetta
turn & release set on rose
50x4mm - FINE

nottolino tedesco

tedesco turn & release

design:
Dnd technical division

ottone
solid brass

finiture / finishes:
OLV OS AB OGC AF OGH
BSS OC OCS ONS FAN ONV



2279
nottolino tedesco
tedesco turn & release



VIS **2402+A**
set nottolino su rosetta
turn & release set on rose
50x7mm - VIS

FINE **2291+A**
set nottolino su rosetta
turn & release set on rose
50x4mm - FINE



B **2286+A**
set nottolino su rosetta
turn & release set on rose
50mm - B

V **2280+A**
set nottolino su rosetta
turn & release set on rose
40x60mm - V



R **2315+A**
set nottolino su rosetta
turn & release set on rose
55mm - FIRENZA

R **2300+A**
set nottolino su rosetta
turn & release set on rose
63x52mm - LATINA



52 **2452+A**
set nottolino su rosetta
turn & release set on rose
52x10mm - 52

nottolino america *america turn & release*

design:
Dnd technical division

ottone
solid brass

finiture / finishes:
OLV OS AB OGC
AF OC OCS ONS FAN



2281
nottolino america
america turn & release



VIS **2403+A**
set nottolino su rosetta
turn & release set on rose
50mm - VIS

VIS **2405+A**
set nottolino su rosetta
turn & release set on rose
50mm - VIS



V **2288+A**
set nottolino su rosetta
turn & release set on rose
40x60mm - V

B **2284+A**
set nottolino su rosetta
turn & release set on rose
50mm - B



FINE **2406+A**
set nottolino su rosetta
turn & release set on rose
50x4mm - FINE

FINE **2407+A**
set nottolino su rosetta
turn & release set on rose
50x4mm - FINE

nottolino joy joy turn & release

design:
Dnd technical division

zama
zamak

finiture / finishes:
ZC ZCS ZNE ZGH ZOR
ZNS ZNE ZBI



JYDN10
nottolino joy
joy turn & release



VIS **RDN22+A**
set nottolino su rosetta
turn & release set on rose
50x7mm - VIS

VIS **RDN24+A**
set nottolino su rosetta quadra
turn & release set on square rose
50x7mm - VIS



FINE **RDN47+A**
set nottolino su rosetta
turn & release set on rose
50x4mm - FINE

FINE **RDN48+A**
set nottolino su rosetta quadra
turn & release set on square rose
50x4mm - FINE

bocchette tonde round escutcheons

design:
Dnd technical division

ottone
solid brass

finiture / finishes:

OLV OS AB AF OGH OGC
OC OCS PCS FAN PGS ONV ONS
OBN ONO ORO PVD PVX



VIS **BD12P / BD12Y**
bocchetta
escutcheon
50x7mm - VIS

45 **BD01P / BD01Y**
bocchetta
escutcheon
45x10mm - dnd



VIS **BD12XP / BD12XY (Inox)**
bocchetta
escutcheon
50x7mm - VIS

52 **BD03P / BD03Y**
bocchetta
escutcheon
52x10mm - 52



FINE **BD40P / BD40Y**
bocchetta 4mm
escutcheon 4mm
50x4mm - FINE

B **BO20P / BO20Y**
bocchetta bombata
rounded escutcheon
50mm - B



VIS **BD35**
bocchetta cieca
blind escutcheon
50x7mm - VIS

VIS **BD36**
bocchetta doppia mappa
escutcheon special key hole
50x7mm - VIS

bocchette quadre square escutcheons

design:
Dnd technical division

ottone
solid brass

finiture / finishes:
OLV OS AB OGH OC PCS ONS
PGS OBN ONO PVD PVX



VIS **BD14P / BD14Y**
bocchetta quadra
square escutcheon
50x7mm - VIS

45 **BD06P / BD06Y ***
bocchetta quadra
square escutcheon
45mm
** su ordinazione/ on demand*



52 **BD04P / BD04Y**
bocchetta quadra
square escutcheon
52x10mm - 52

52 **BD05P / BD05Y**
bocchetta quadra smussata
chamfered square escutcheon
52x10mm - 52



FINE **BD41P / BD41Y**
bocchetta quadra 4 mm
square escutcheon 4 mm
50x4mm - FINE



VIS **BD37**
bocchetta quadra cieca
blind square escutcheon
50x7mm - VIS

VIS **BD38**
bocchetta quadra doppia
mappa / square escutcheon
special key hole
50x7mm - VIS

bocchette speciali special escutcheons

design:
Dnd technical division

ottone
solid brass

finiture / finishes:

OLV OS AB OGC AF OGH
OC OCS PCS ONS FAN PGS ONV
OBN ONO PVD PVX



S **BO16P / BO16Y**
bocchetta
escutcheon
30x60mm

S **BD16P / BD16Y**
bocchetta rettangolare dnd
dnd rectangular escutcheon
30x60mm



B **BF10P / BF10Y**
bocchetta fiorenza
fiorenza escutcheon
55mm

OGH
ONV
OROF
ORO

bocchette speciali special escutcheons

design:
Dnd technical division

ottone
solid brass

finiture / finishes:

OLV OS AF AB OGC OGH
FAN PGS ONV PVD



R **BD30P / BD30Y**
bocchetta cassia
cassia escutcheon
50x60mm

R **BD31P / BD31Y**
bocchetta ardea
ardea escutcheon
45x50mm



R **BO42P / BO42Y**
bocchetta latina
latina escutcheon
45x50mm

V **BO14P / BO14Y**
bocchetta ovale
oval escutcheon
40x60mm



R **BD32P / BD32Y**
bocchetta lucrezia
lucrezia escutcheon
50x6mm - FINE

R **BD33P / BD33Y**
bocchetta lucrezia
lucrezia escutcheon
50x6mm - FINE

OLV
OGH
OC
PGS

fermaporta door stop

design: ottone
Martinelli Lab solid brass

finiture / finishes:
OLV OC OCS PCS ONS OGH OGS



2268/1
fermaporta classic a parete
classic on wall door stop
35x87



2268
fermaporta classico a
pavimento / *classic on floor*
door stop
42x96mm

AF
OS
ORO
OLV
OC
OCS
OGH

chiavi keys

ottone stampato a caldo
hot stamped brass

finiture / finishes:
OLV OC OCS
PCS ONS OGH OGS



DO1C
chiave dolce
dolce key



V11C
chiave vita
vita key

supporto corrimano handrail bracket

ottone
solid brass

finiture / finishes:
OLV OGC OC OCS



2263
supporto corrimano
handrail bracket



RI200
fermaporta ring
ring door stop
30x30mm



2265
fermaporta cilindro
door stop
29x45mm



2264
fermaporta chiocciola
door stop
45mm



2266
fermaporta inox
inox door stop
20x20mm

INOX

cerniere – copricerniere hinges – cover hinges

ottone
solid brass

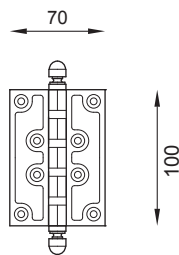

2307
cerniera classic
classic hinge

OLV
OS
AF
AB
OGC
OGH
FAN

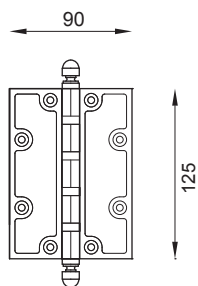

2307/1
cerniera classic
classic hinge

OLV
OS
AF
AB
OGC
OGH
FAN

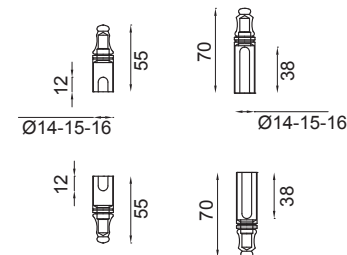

2313
set copricerniere corto con
piramide / short cover hinges
set with pyramid

2313/2
set copricerniere lungo con
piramide asole lunghe / long
cover hinges set with pyramid
long holes

OLV
OS
AF
AB
OGC
OGH
FAN

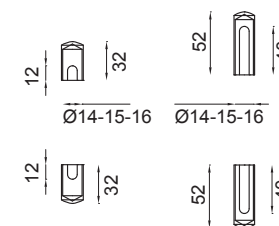

2314
set copricerniere corto piatto
flat short cover hinges set

2314/2
set copricerniere lungo con
asole lunghe e corte / long
cover hinges set with long or
short holes

OLV
OC
OCS
ONS

placche plates

ottone
solid brass



PL829 latina
57x265mm

PL570 classic
46x252mm

PL310 noxia
40x251mm

PL169 quadra
42X245mm



PL580 cassia
55X250mm

PL560 ardea
48X252mm

PL520 fiorenza
65X320mm

PL550 lucrezia
53X300mm



PLD01 dnd
245mm

PL279 sabina
38X236mm

PL590 arcadia
37X237mm

PL390 daniela
40X247mm



PL400 slide
35X160mm

PL283 sabina
35X175mm

PL394 daniela
37X170mm

PL401 slide q.
35X160mm

espositori *displays*

ESP204
espositore da parete
wall display

ESP214
espositore totem bifacciale
two sides display

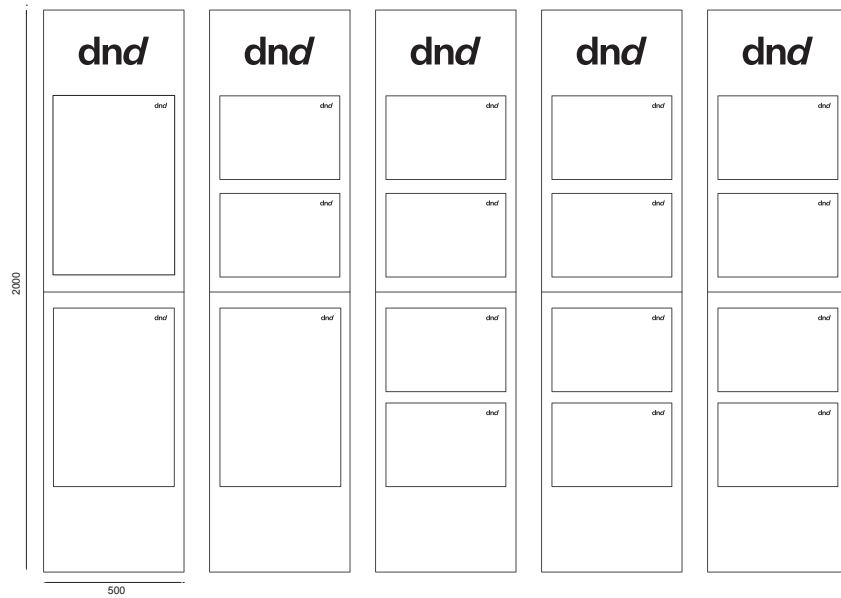
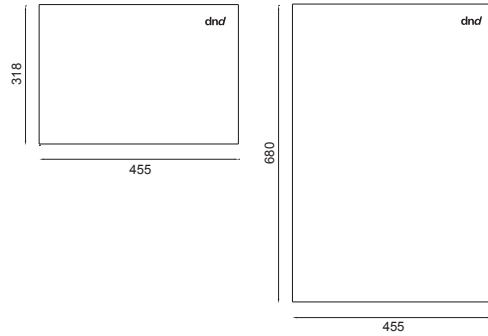

Progetto grafico /
Graphic design
Leonardo Sonnoli
Irene Bacchi
- **Studio Sonnoli** -

Stampa / *Printing*
Fly Color Srl

Dnd
è un marchio di
is a trademark of

FMN Martinelli S.p.A.
Località Piani di Mura, 2
25070 Casto (BS) - Italia

© 2018 FMN Martinelli S.p.A.

Tutti i diritti riservati
All rights reserved

Dnd
Località Piani di Mura, 2
25070 Casto (BS) - Italia

T +39 0365 899113
F +39 0365 899118

www.dndhandles.it



dnd

handles
with care

dndhandles.it

